

★ **STAR** ★

*High Quality Low Voltage
Vehicle Swing Gate Operator
Solar or AC Charged*

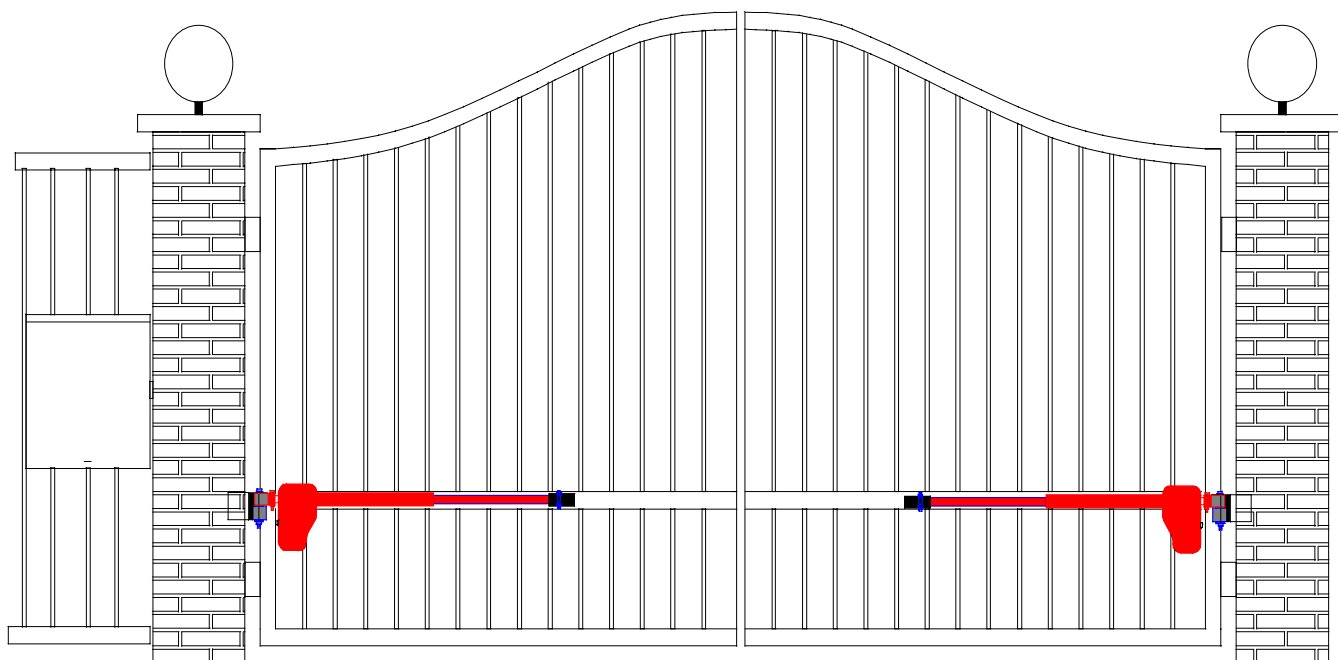

STAR I Single Swing Gate Operator

STAR II Dual Swing Gate Operator

Installation/Owners Manual



PROUDLY MADE IN THE USA
WWW.USAUTOMATIC.COM



INTRODUCTION

This operator is intended to be installed on vehicular Class I or Class II gates as defined by UL 325. Maximum gate load not to exceed 300 pounds.

PLEASE READ THIS ENTIRE MANUAL CAREFULLY PRIOR TO INSTALLATION. In doing so, along with performance of the installation in step-by-step order, you will achieve optimal results. We strongly recommend that all installation and service personnel pay particularly close attention to the safety systems section of this manual and UL325. In addition to the current sense feature that is provided, other safety devices are necessary to make each particular installation as safe as possible to reduce the risk of personal injury and/or property damage. A trained and authorized service technician or the factory should be consulted for assistance.

Cautions - Very Important

- ⇒ Do not attempt to enter the gate area while the gate is moving. Wait until the gate comes to a complete stop.
 - ⇒ Operate the gate only when it is fully visible, free of persons or obstructions, and properly adjusted.
 - ⇒ Do not allow children to play in the area of the gate. Do not allow anyone to ride on the gate.
 - ⇒ Do not allow children to play with the remote control or any other activation device.
 - ⇒ Do not attempt to "beat the gate" while the gate is opening or closing. This is extremely dangerous.
 - ⇒ Test the current sense feature and all safety devices regularly to insure correct operation.
 - ⇒ Study the entire Safety Section, paying particularly close attention to the Entrapment zones on pages 24-26 and be aware of these areas not only during use but also during any adjustments to the unit.
- Other Safety Standards**
- ⇒ All control stations should be located at least 6 feet from any moving part of the gate or operator.
 - ⇒ Do not ever install any control device where a user will be tempted to reach through the gate or fence to activate a gate.

© USAutomatic, Inc., 2000

All rights reserved. No part of this may be reproduced by any means without the expressed written consent of the publisher.

Table Of Contents

	<u>Page</u>
Introduction	1
Table of Contents	2
General Requirements/Gate Qualifications & Applications	3
Importance of a Properly Designed Gate.....	4
Mounting Site Review	4
Parts Included List	5
Hinge Mount Tube Installation/Pull to Open	6
Hinge Mount Tube Installation/Push to Open	7
Hinge Mount Tube Installation/Vertical Height.....	8
Preparation of Actuator.....	9
Actuator Installation.....	10
Mounting the Gate Bracket / Control Box Installation.....	11
Master/Slave Dual Gate Wiring.....	12
Charging Source Installation – Solar / AC	13
Final Adjustments	14
Current Sense Adjust	15
Limit Switches	16
Circuit Board & Terminal Description.....	17
Function Jumper Settings.....	18
Push to Open Modifications / Emergency Manual Release	19
Safety Section	20-26
Troubleshooting	27-30
Accessory Wiring Diagrams	31-37
Magnetic Wire Sensing Loops.....	38-41
Warranty Statement	Back Cover

GENERAL REQUIREMENTS

General hand/tools such as combination wrenches, tape measure, level, clamps, etc. are required. Your particular installation may require a drill or other hardware not provided. Welding by a qualified welder is the recommended method of securing the linear actuator mounts to the gate and hinge post. Bolt on brackets are an option, but they must be very securely attached (i.e. carriage bolts with lock nuts and washers). Lag type bolts are not recommended. Loose or unstable operator mounts will result in improper operation.

BATTERY REQUIRED FOR OPERATION (NOT INCLUDED).

We recommend a 12-volt deep cycle marine battery. The cable harness supplied with the operator is designed for bolt type adapters such as ones found on most marine batteries.

IMPORTANT CAUTIONS:

1. Do not perform any welding with the actuator cable plugged into the control board or the battery connected. Serious damage to the control board and/or battery will occur if attempted.

GATE QUALIFICATIONS/APPLICATIONS

GATE LENGTH/WEIGHT

This gate operator is rated for vehicular class I and class II swing gates up to 12 feet in length and up to 300 pounds in weight as defined by UL325. If your gate exceeds either one of these limits, please consult a qualified technician or the factory for alternative solutions. (Example: convert one 20' gate into two 10' gates and use dual gate operators.)

Note: *The total gate opening normally cannot exceed 110 degrees.
Consult a service technician or the factory if greater opening is required.*

GATE CYCLES PER DAY

Solar charged systems should not exceed 25 complete open/close cycles per day without additional solar panels. This actuator type opener, whether AC or Solar charged, should never be used in applications which exceed 100 complete open/close cycles per day. Cycles can be decreased by holding the gate open during high cycle time periods. If more cycles are required, a high traffic gate opener should be used.

IMPORTANCE OF A PROPERLY DESIGNED GATE

As a general rule a gate, which is to be automatically operated, must be stronger and smoother than one, which will be manually operated. Since the gate is a major component of the system, great care and concern must be given to the gate design.

A GATE OPERATOR CANNOT OVERCOME A POORLY DESIGNED GATE.

- A. Does the gate swing smoothly without binds or excessive resistance? Swing gates should swing level and plumb to prevent the operator from having to lift the gate open or closed. Swing gates should not require a wheel to support them. Wheels usually create drag, which will cause operator problems. A wheel is generally a sign of a weak hinge system or a weak gate frame.
- B. Is the gate frame of substantial strength without excessive weight? Will the frame withstand normal wind load conditions without sway or vibration? Will the gate hit the catch correctly without being hand-guided or lifted into the catch?
- C. Are the hinges suited for the number of cycles expected per day? We recommend bearing type hinges to reduce friction drag.
- D. Will a reinforcement brace be required to attach the operator to the gate or does a suitable cross member exist in the gate design?

If any of these problems exist, they must be corrected to achieve a reliable automatic gate system.

MOUNTING SITE REVIEW

Installers should ask themselves these questions prior to installation and predetermine the solution to any problems, which may occur.

- A. Does sufficient space exist for mounting and future servicing of the operator and control box?
- B. Will the unit push the gate open to the outside or pull the gate open to the inside?
- C. How will the actuator mounts be secured at the hinge and to the gate?
- D. How will the control box be mounted securely enough to support the weight of the battery and can it be located within 8 feet to prevent splicing of the actuator cable?
- E. How will power be brought to the control box if AC charged?
- F. How and where will the solar panel mount if solar charged so that optimum sunlight is received?
- G. How will exterior control wiring, if any, be brought to the control box?
- H. Have all safety concerns been addressed? (See Safety Section Pgs. 20-26)

PARTS INCLUDED

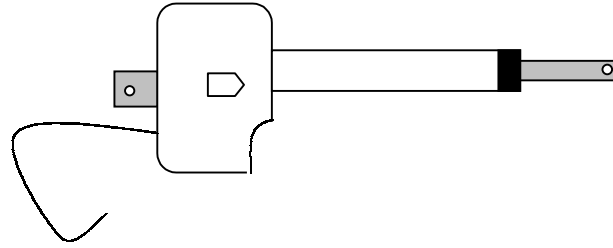
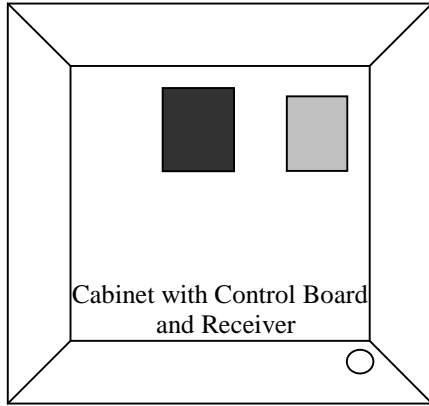

*Actuator Arm with 8 foot of cable

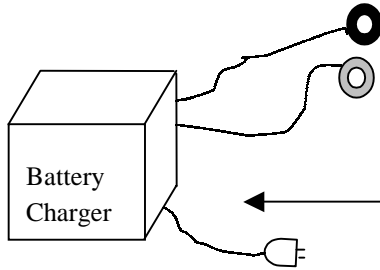

OR

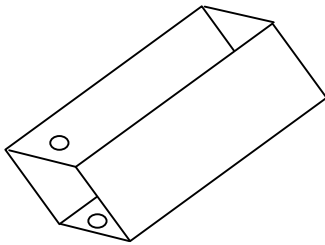
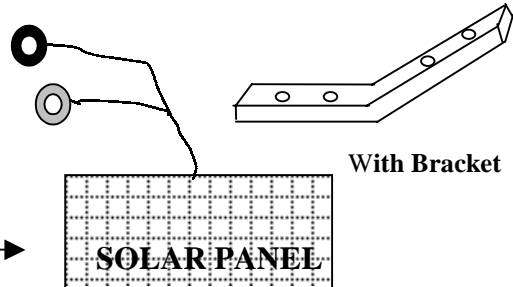

2" x 2" x 12"
*TUBE

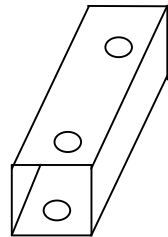

1 1/4" x 1 1/4" x 3 1/8"
*TUBE

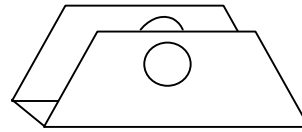

*GATE BRACKET

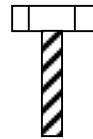

*1-BOLT
1/2" X 2"

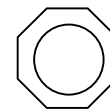

*2-LOCKNUT
1/2"

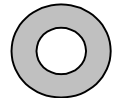

*3-WASHER
1/2"

*1-MANUAL RELEASE PIN
AND CLIP

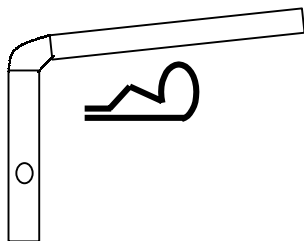

2-PLACARDS

*1-BOLT
1/2" X 4 1/2"



- *For Star II quantity is doubled.
- Additionally, 30' of Master/Slave Actuator cable provided with the STAR II
- Placards should be visible from inside and outside of gate.

NOTE: 12 Volt DC deep cycle marine battery required. (Not Included)

STEP 1 Hinge Mount Tube Installation (Part 1)

PULL TO OPEN / TOP VIEW (SEE NEXT PAGE FOR PUSH TO OPEN)
 (Left-handed installation shown. Reverse for right-handed installation)

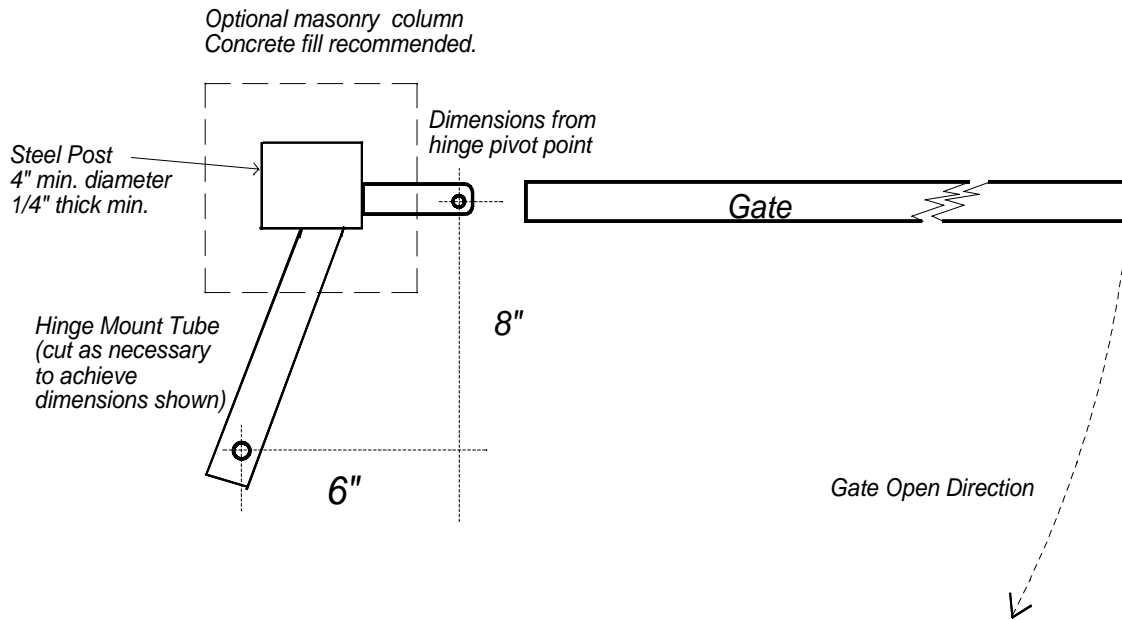
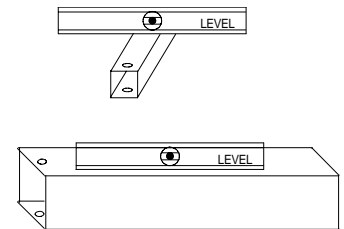
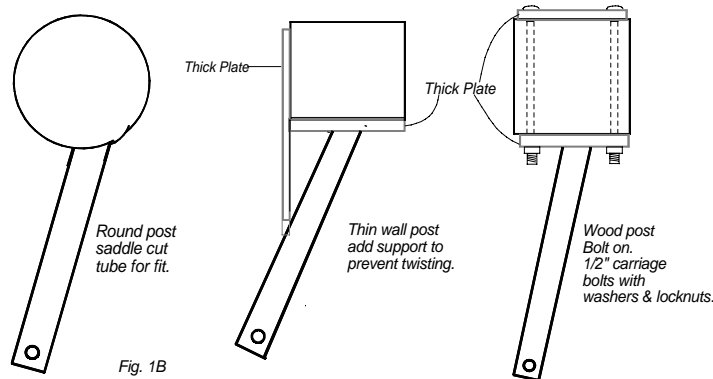

Fig. 1A

Hinge Mount Tube must be level in all directions for proper alignment and operation.

Other Typical Methods For Pull to Open



Regardless of method used, the hinge mount tube should be very secure since the entire force of the gate is directed to this mount. The post must be of adequate strength to resist twisting as well.

Conform to dimensions shown at top of page in all cases. See page 8 to locate height of hinge mount tube on post.

Note: *USAutomatic is not responsible for failure to comply with UL325 standards, local building codes or improper installations.*

STEP 1 Hinge Mount Tube Installation (Part 1)

PUSH TO OPEN / TOP VIEW (SEE PREVIOUS PAGE FOR PULL TO OPEN)
 (Left-handed installation shown. Reverse for right-handed installation)

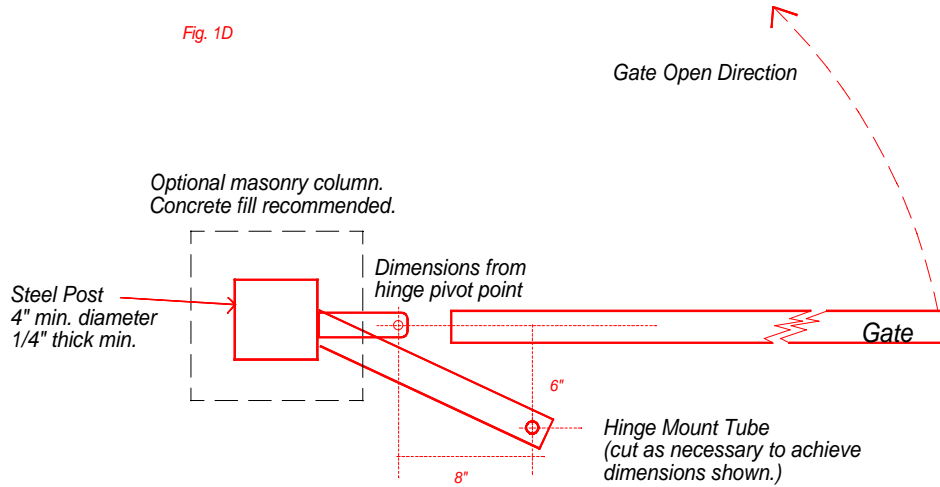

Other Typical Methods for Pull to Open

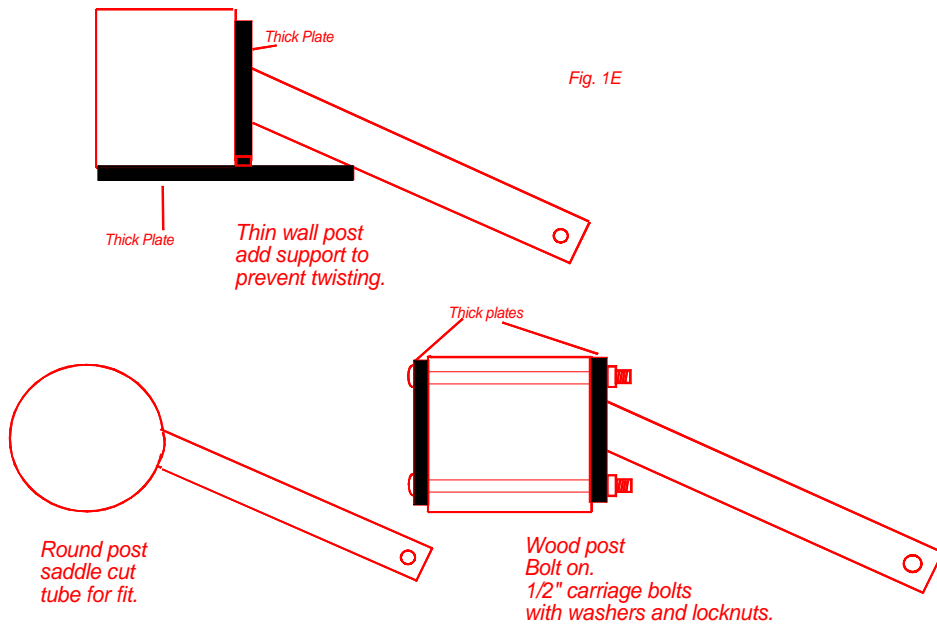

Hinge Mount Tube must be level in all directions for proper alignment and operation.

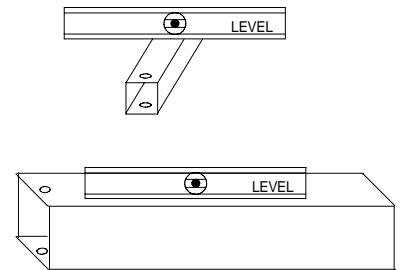

Regardless of method used, the hinge mount tube should be very secure since the entire force of the gate is directed to this mount. The post must be of adequate strength to resist twisting as well.

Conform to dimensions shown at top of page in all cases. See page 8 to locate height of hinge mount tube on post.

Note: *USA Automatic is not responsible for failure to comply with UL325 standards, local building codes or improper installations.*

STEP 1 Hinge Mount Tube Installation (Part 2)

VERTICAL HEIGHT POSITIONING

Refer to figures 2B-2F to determine the best location for the actuator on the gate. Then use figure 2A to determine the height of the hinge mount tube and gate bracket. The middle of the gate is the ideal location for the actuator. The top or bottom of the gate frame are also possible locations.

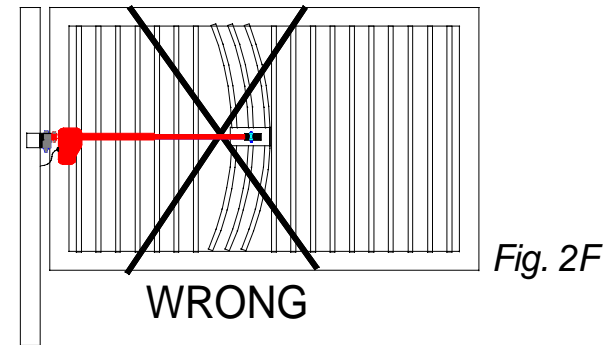
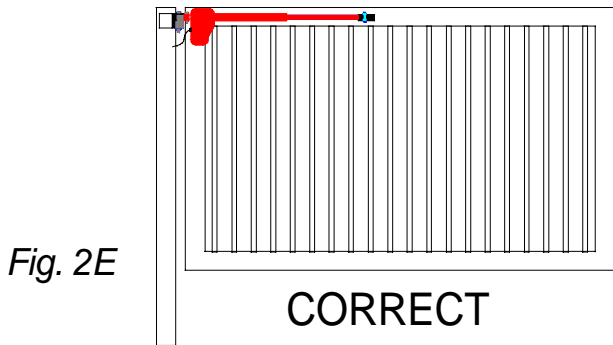
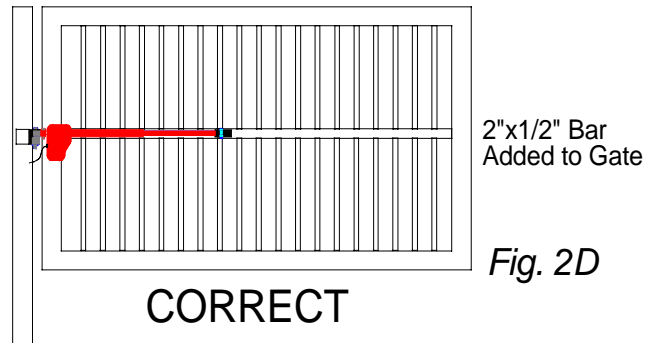
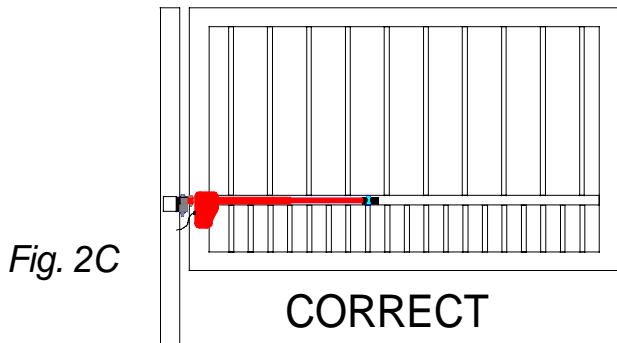
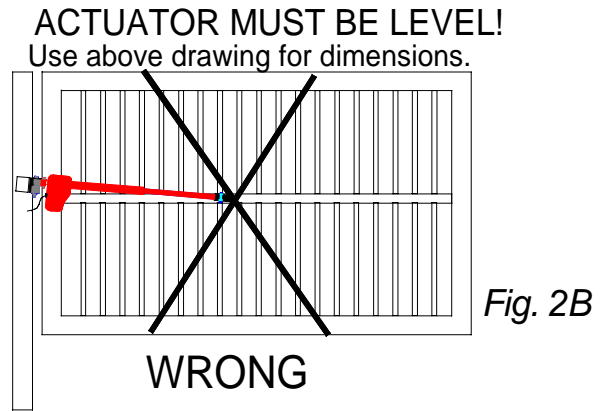
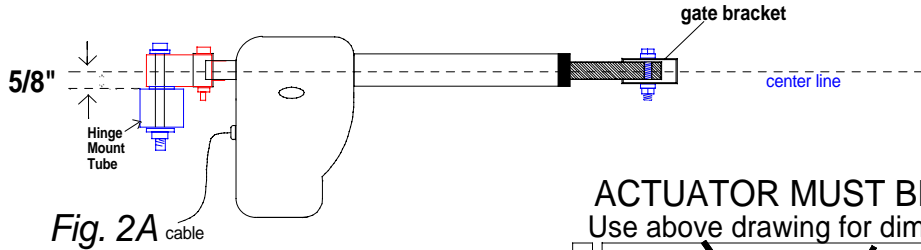

The gate bracket must be welded in an area that can withstand the full force of the gate. Do not simply weld across a few pickets or bending of the pickets will occur. Add a cross bar if necessary or weld the bracket to a piece of gate frame.

STEP 2 Prepare Actuator for Installation

Assemble the actuator to the extension tube as shown in figure 3A.

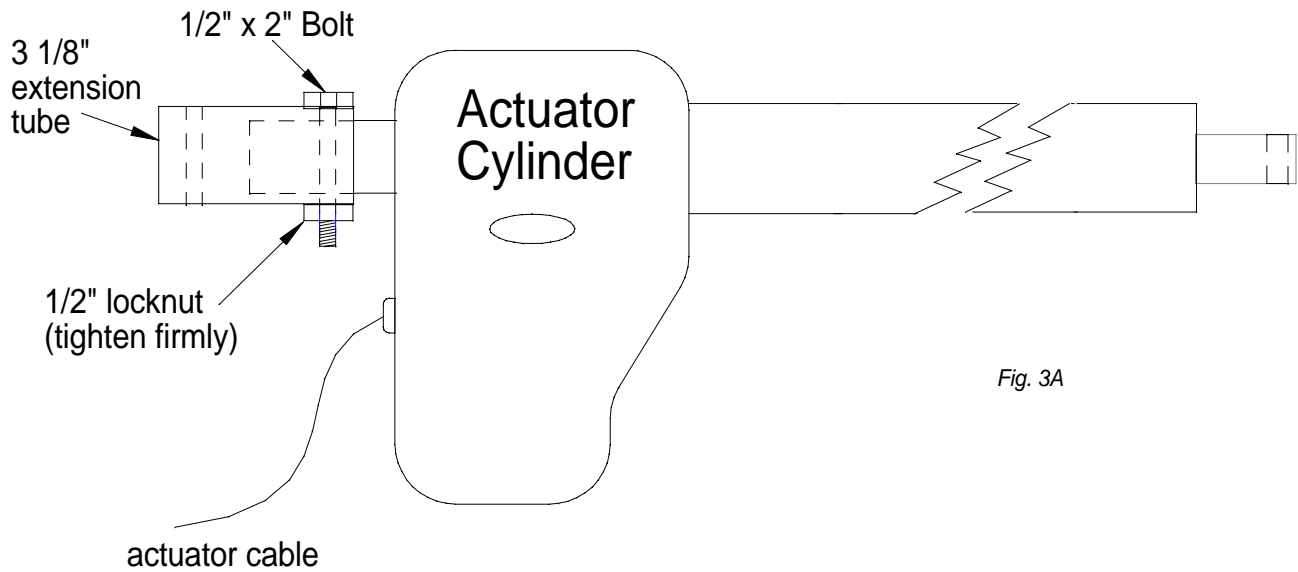

Now assemble the actuator to the gate bracket as shown in figure 3B

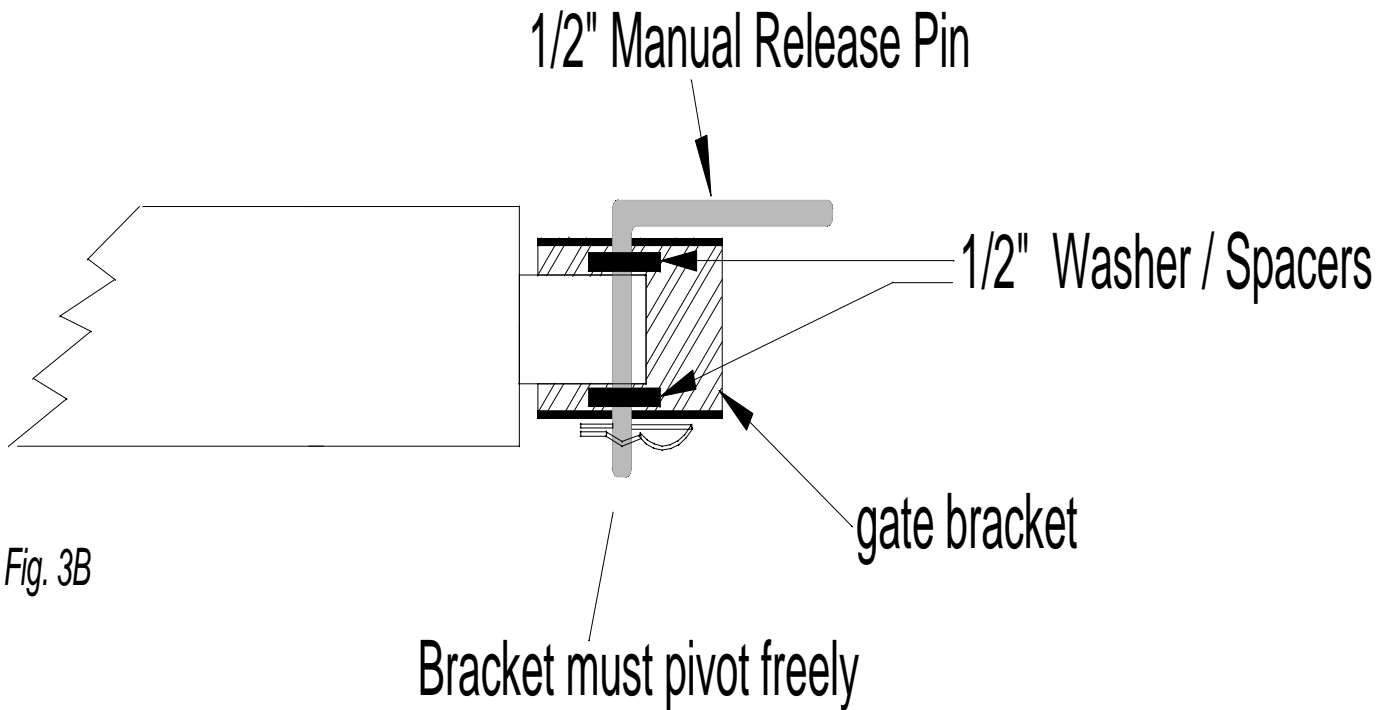

STEP 3 Actuator Installation

Mount the actuator to the hinge mount tube as shown in Figure 4B. Support the free end of the unit while mounting.

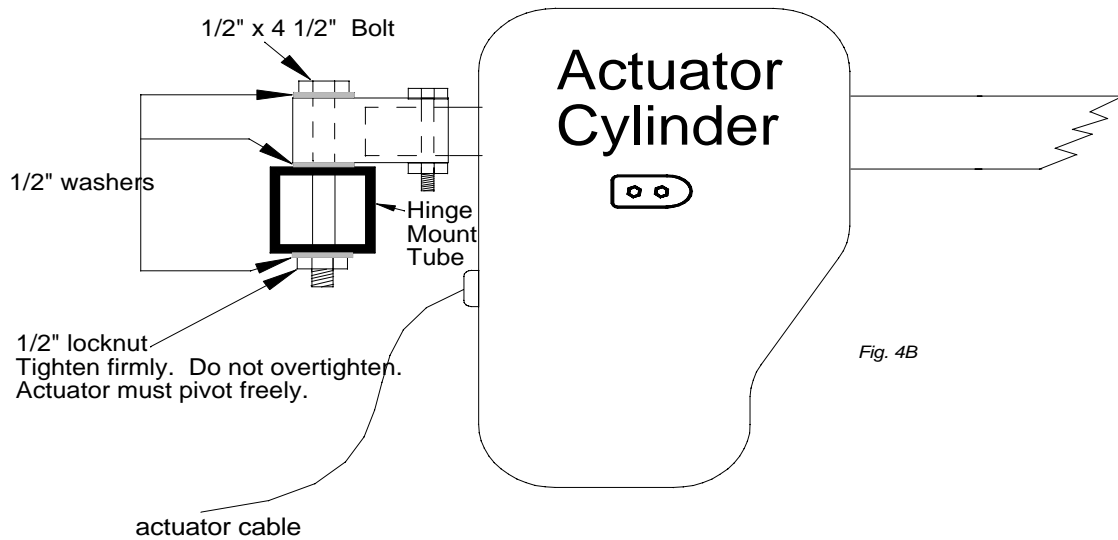

Do not permanently mount the actuator upside down. Mount only as shown in the illustrations.

NOTE: *With Push to Open or right hand applications, the actuators may temporarily be mounted upside down for ease of limit adjustments.*

Open the gate to the desired OPEN position and block in place to secure the gate.

NOTE: *The total opening cannot exceed 110 degrees. Consult a service technician or the factory if greater opening is required.*

Clamp the gate bracket to the gate at the previously determined point and weld to gate. Be sure that your gate does not move while clamping. The location of the gate will set your open position. The cylinder will be level if all steps were performed accurately.

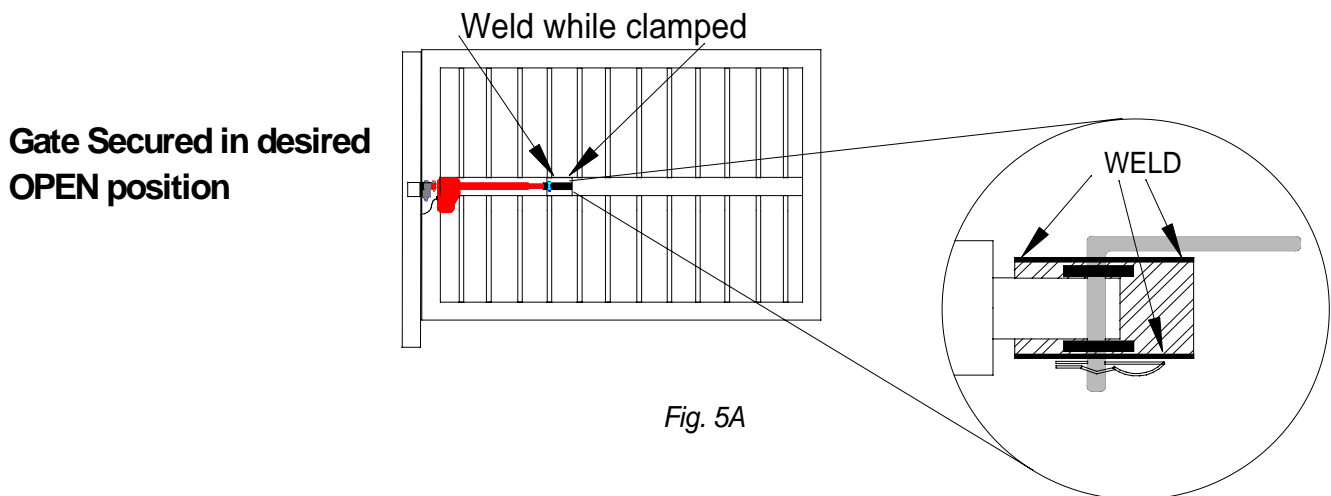

STEP 3 Mounting of Gate Bracket (PUSH to Open Only)

Close the gate to the desired CLOSED position and block in place to secure the gate.

NOTE: *The total opening can not exceed 110 degrees. Consult a service technician or the factory if greater opening is required.*

Clamp the gate bracket to the previously determined point and weld to gate. Be sure that your gate does not move while clamping. The location of the gate will set your closed position. The cylinder will be level if all steps were performed accurately.

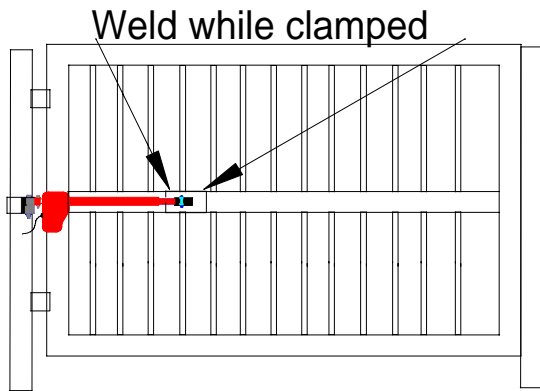

Fig. 5B

**Gate secured in desired
CLOSED position**

STEP 4 Mounting Control Box

Mount the control box at the determined location. The actuator cable is 8' in length. Keep this in mind when choosing the location. If the cable must be lengthened, use proper wiring and connectors in watertight boxes or control board damage may result (see drawing on page 12). If mounting holes must be drilled, be careful not to get drill shavings on the control board. If welding, be careful not to damage the control board with excessive heat. After box has been securely mounted, run the actuator cable into the control box through the hole in the bottom tray and plug securely into control board.

NOTE: *Push to open installations requires a USAutomatic adapter for each actuator. See page 19 for more details.*

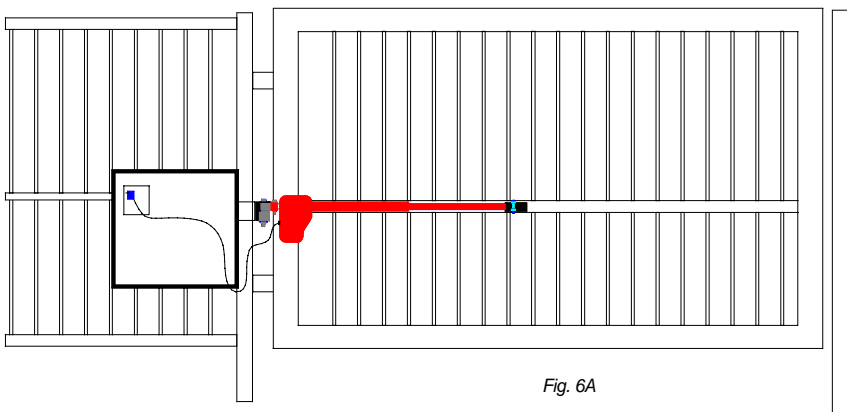
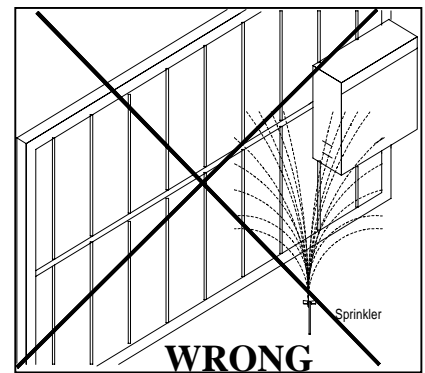

Fig. 6A



Do **not** mount in areas by automatic sprinklers, or flood-prone areas. It is important that the control board, control devices, and the battery compartment remain dry.

Splicing For Actuator Cable (only if required)

STAR I Single Gate Wiring

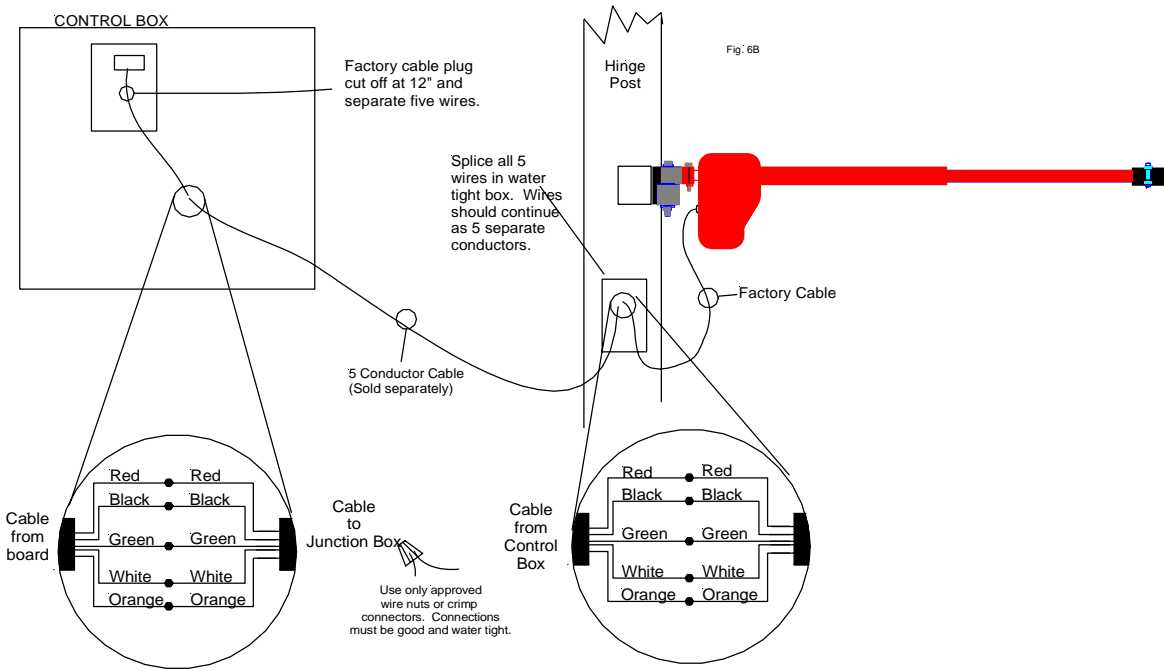

STAR II Dual Gate Wiring

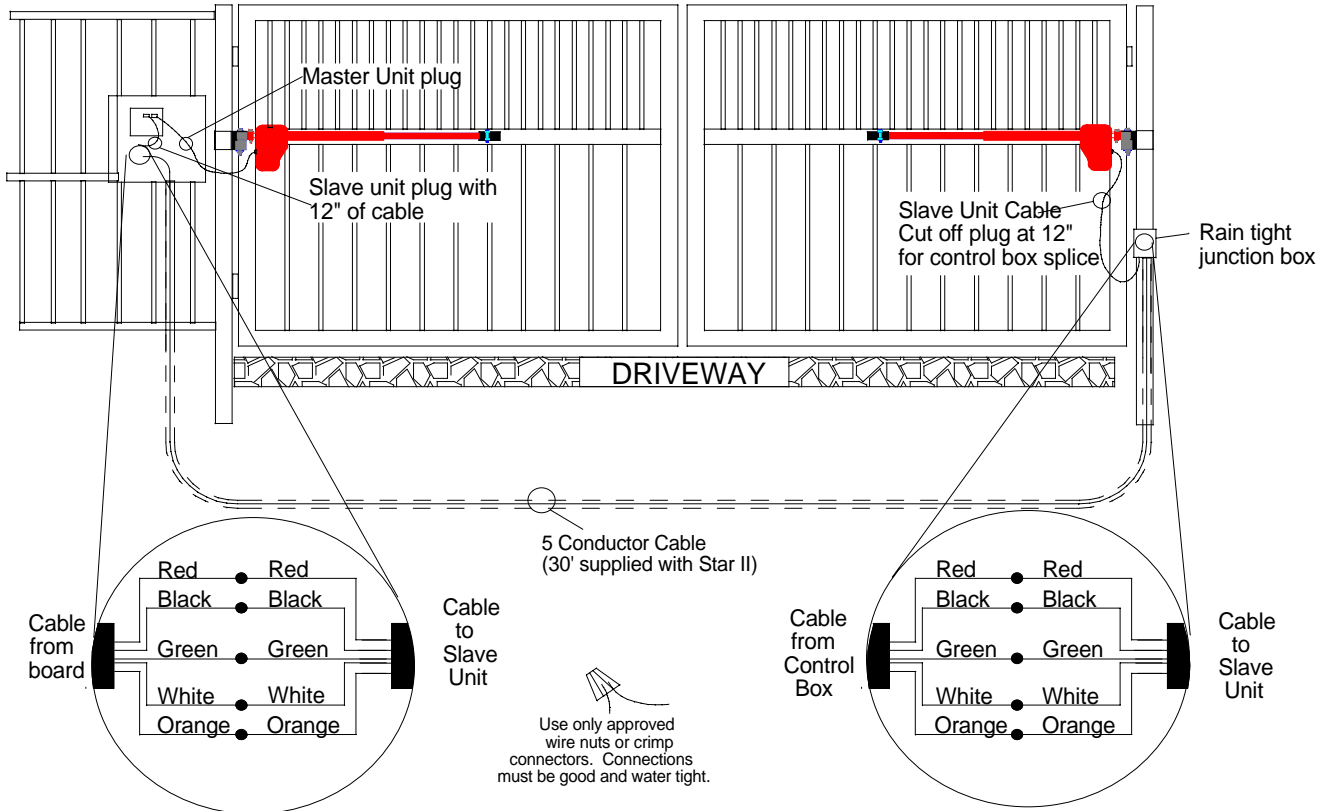

STEP 5 Installation of Charging Source

SOLAR PANEL

Locate and mount the solar panel bracket so that the panel faces southwest and maintains the preformed 45-degree angle. The standard cable is 10' in length and must feed in through the bottom of the control box. Pay attention to the distance when determining you're mounting location. Although the cable can be extended with watertight connectors, charging power is diminished. Sometimes it is necessary to locate the panel farther away to achieve optimum sunlight, but consider that optimum sunlight might not mean optimum charging if the distance is too great. Use #16 gauge wire or larger and keep length as short as possible.

Assemble panel to bracket with supplied hardware.

Star I or Star II

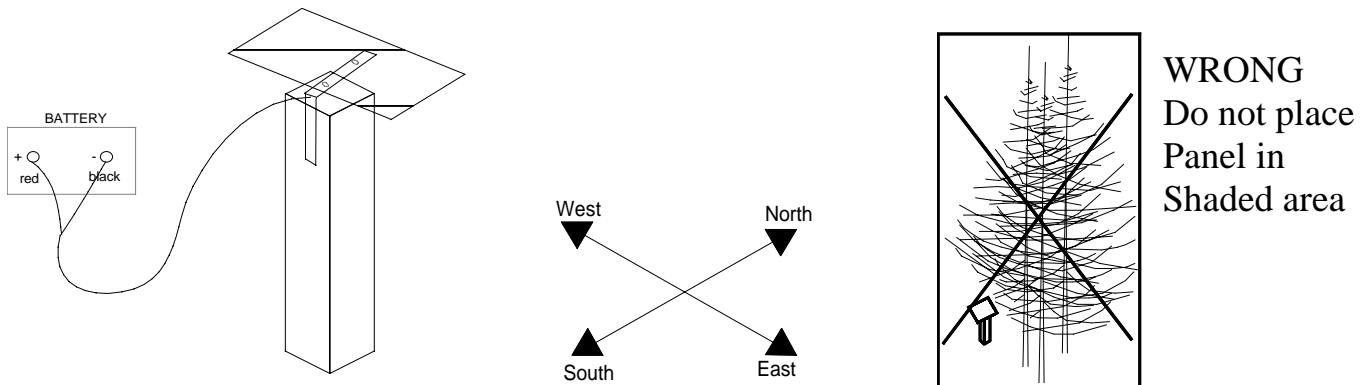

AC CHARGER

Locate and install the AC battery charger inside the control box. The charger requires a receptacle for 110-volt AC supply: recommended location is inside the control box. The receptacle should be installed by a licensed electrician per local building codes.

Note: *USAutomatic recommends an AC surge protector on the 110-volt line be utilized in lightning prone areas.*

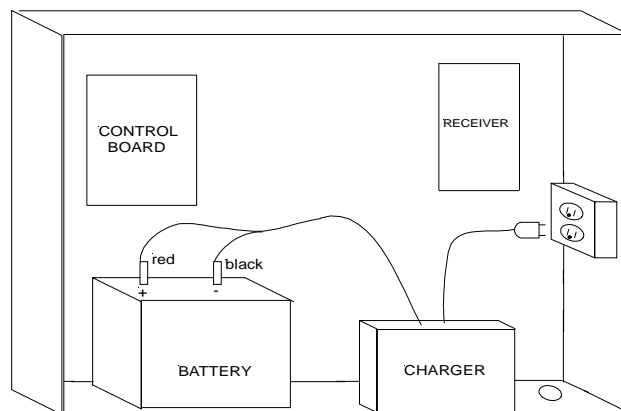

Fig: 7B

***Do not hook up battery wires from actuator/control board cable at this time.**

STEP 6 Making Final Adjustments

In order to make final adjustments, a signal device such as a radio control should be used. The control board is equipped with a pushbutton for this purpose. The button is designed to give an open/close signal. The gate will open if closed or close if in the open position. A signal in mid-travel will stop the gate.

- If your unit was purchased with a radio receiver, it is important that you change the dipswitch code settings on your receiver and on all of your transmitters. Please read the instructions found with your transmitter or consult a dealer for assistance.

IMPORTANT NOTES

1. Locate the actuator cable plug and be aware that you may need to disconnect it if the cylinder over travels the desired stop points. You should be able to stop the motor with a signal from your device without having to disconnect the plug, but in cases of incorrect wiring, the plug can be used as an emergency power shut-off.
2. Locate the sensitivity adjustment. We intentionally set the sensor at a highly sensitive setting. This may need to be adjusted to achieve gate movement without tripping the sensitivity circuit and causing the gate to reverse direction. See page 15 for details.
3. Study the limit switch section and instructions on adjusting the limit switches prior to battery hook up. See page 18 for details.

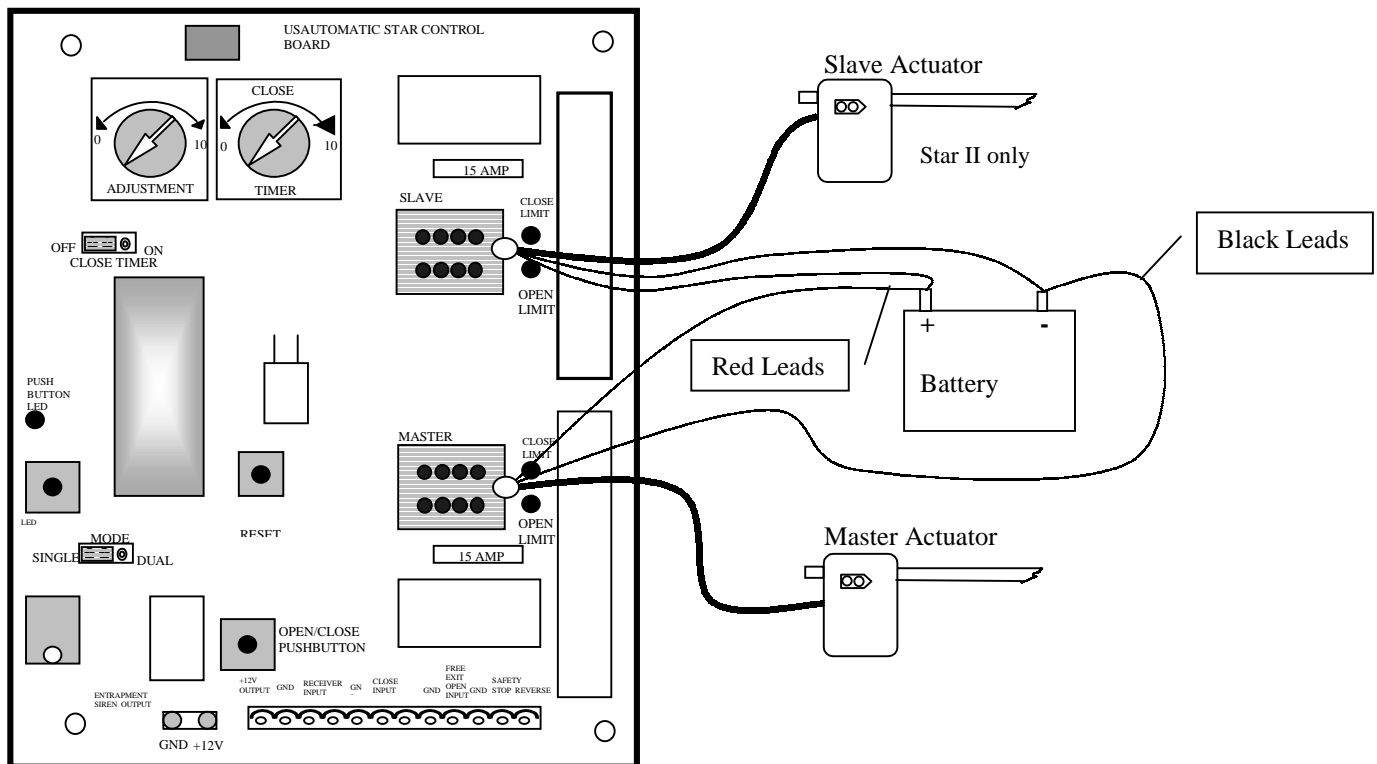

If you have an understanding of the current sense feature, how to disconnect the actuator plug in an emergency, and how to adjust the limit switches, then proceed to hook up the battery leads and connect the plug to the board. The red battery lead goes to the positive + terminal on the battery and the black lead goes to the negative - terminal on the battery.

Current Sense Adjust

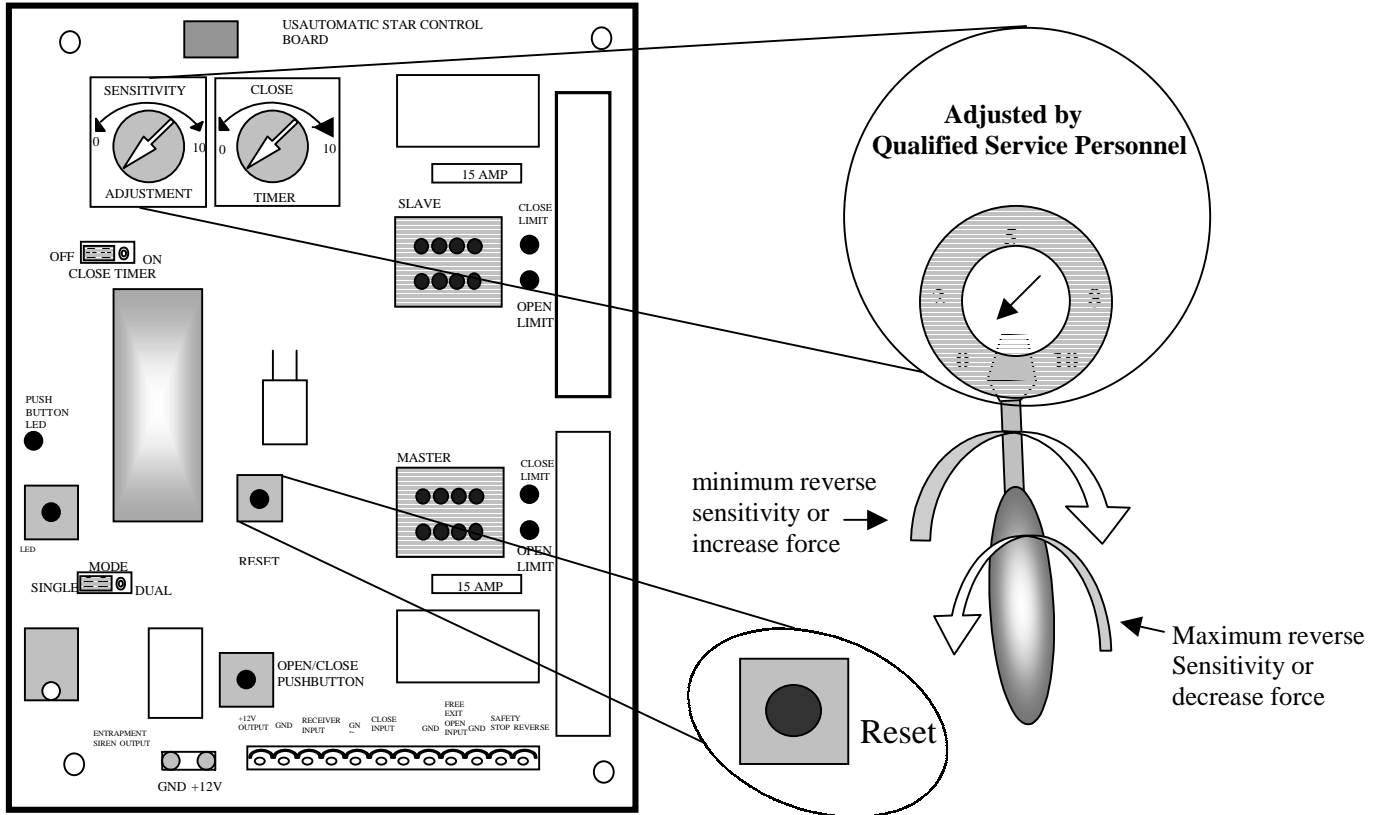

- Adjust the current sensor so that the gate reverses when it hits a solid object. Do not turn the dial beyond the stop points at 0 and 10.
- If current sensor is activated twice before reaching a fully open or close position the operator will stop operating and require a manual reset using the reset button on the control board.
- Remember if the gate reverses direction when operating without hitting and obstruction, then minimizing sensitivity (increasing pressure) may be required. Do not increase any more than necessary.

CAUTION: To reduce the risk of injury, USAutomatic strongly recommends the installation of additional safety devices such as Photo Eye Sensors and Safety Edges. Consult an authorized installing dealer or the factory for a complete explanation of options and see the Safety Section of this manual on pages 20 to 26.

LIMIT SWITCHES

The limit switch adjustments are located on the side of the actuator. Remove the dust plug to make adjustments. The normal settings from the factory allow for 12" of travel (approx. 70° opening). You will most likely have to adjust the limits for your installation. The adjustments are labeled "Extend" and "Retract" on the dust plug. A 7/32" socket or nut driver is required.

NOTE: *ALL ADJUSTMENTS SHOULD BE MADE IN THE MID TRAVEL (1/2 OPEN) POSITION. DO NOT FORCE THE ADJUSTMENT SCREWS TO TURN BEYOND THEIR MAXIMUM TRAVEL! FORCING WILL DAMAGE THE LIMIT ASSEMBLY. REMOVE THE ADJUSTMENT TOOL AFTER EACH ADJUSTMENT.*

Side view of Actuator:

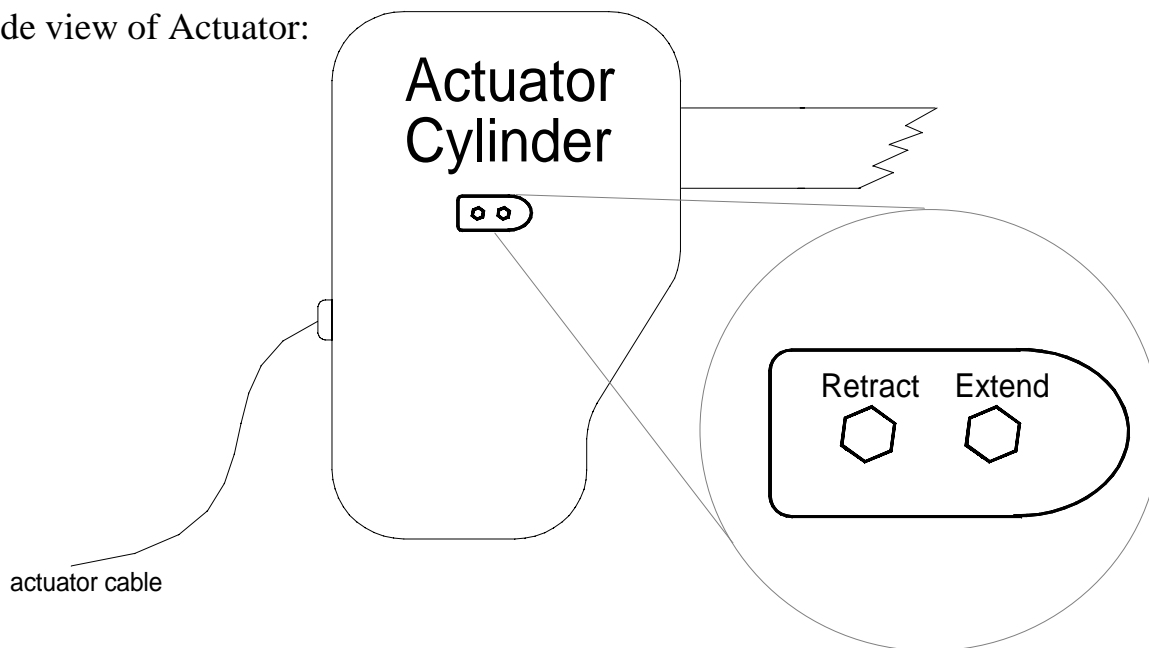

The following will assist you. Shown below are adjustments for pull to open installations.

To extend more or close gate more. Turn the extend adjust counter clockwise.

To extend less or close gate less. Turn the extend adjust clockwise.

To retract more or open gate more. Turn the retract adjust clockwise.

To retract less or open gate less. Turn the retract adjust counter clockwise.

- Remember if the gate reverses direction without hitting an obstruction, then minimizing sensitivity (increasing pressure) may be required. Do not increase any more than necessary.

Circuit Board & Terminal Description

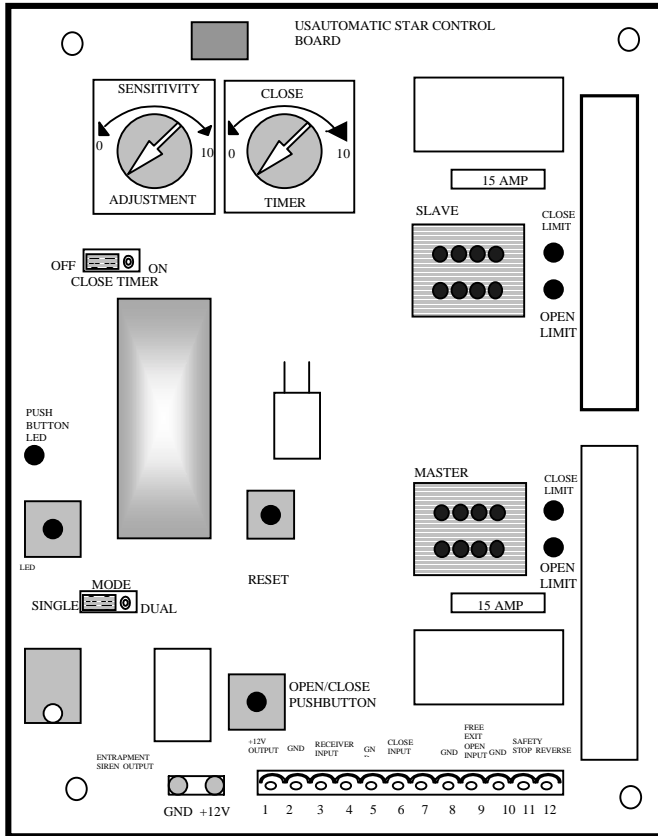

TERMINAL

DESCRIPTION

- | | |
|----|--|
| 1 | + 12 volt DC Output
Maximum current output 1.5 amp (1500 milliamps) |
| 2 | Common Ground Input |
| 3 | Receiver Input. (normally open)
Push button, radio control, keypad, etc. |
| 4 | Not used |
| 5 | Common Ground Input |
| 6 | Close input (normally open) |
| 7 | Not used |
| 8 | Common Ground Input |
| 9 | Free Exit/Open Input (normally open contacts) free exit loop input or any hold open input such as a 7-day timer, telephone access unit, or maintain contact switch (normally open contacts). These devices open the gate and will prevent the gate from closing if the contact is maintained. Once the contacts have been released, the gate can be closed with a closing signal device or the automatic close timer feature. |
| 10 | Common Ground Input |
| 11 | Safety Stop (normally open). Stops a moving gate. |
| 12 | Safety Reverse (normally open) Secondary Entrapment Device Input |

Function Jumper Settings

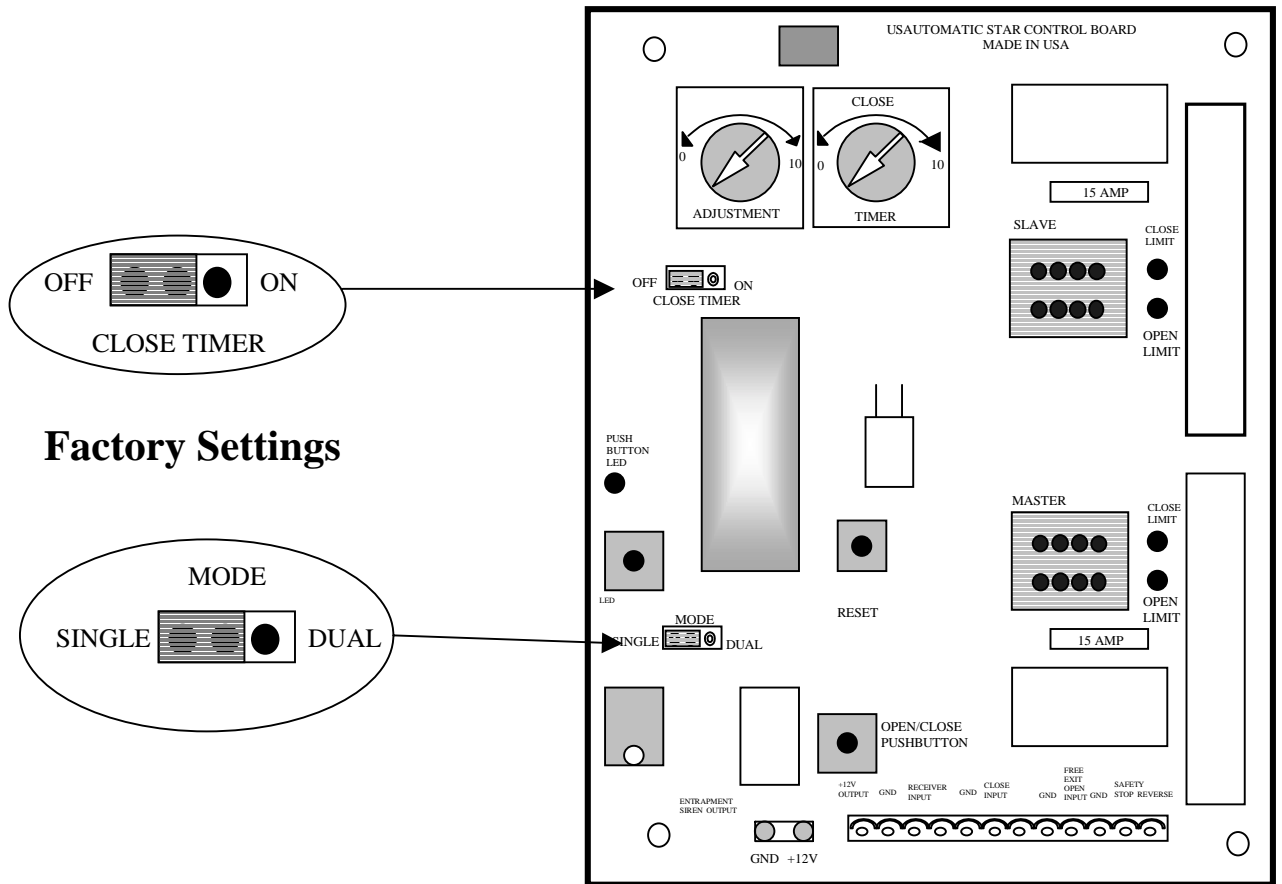

Factory Settings

Factory settings are shown in bold italic type

- S3 Automatic close timer circuit
ON Timer to close is activated
OFF *Timer to close is disabled (Factory setting)*
- S2 Mode Select (SINGLE/DUAL)
SINGLE *Single Gate Jumper Setting (Factory setting)*
DUAL Dual Gate Jumper Setting

Push to Open Cable Modifications

Preferred Method

Cable Plug (sold separately)

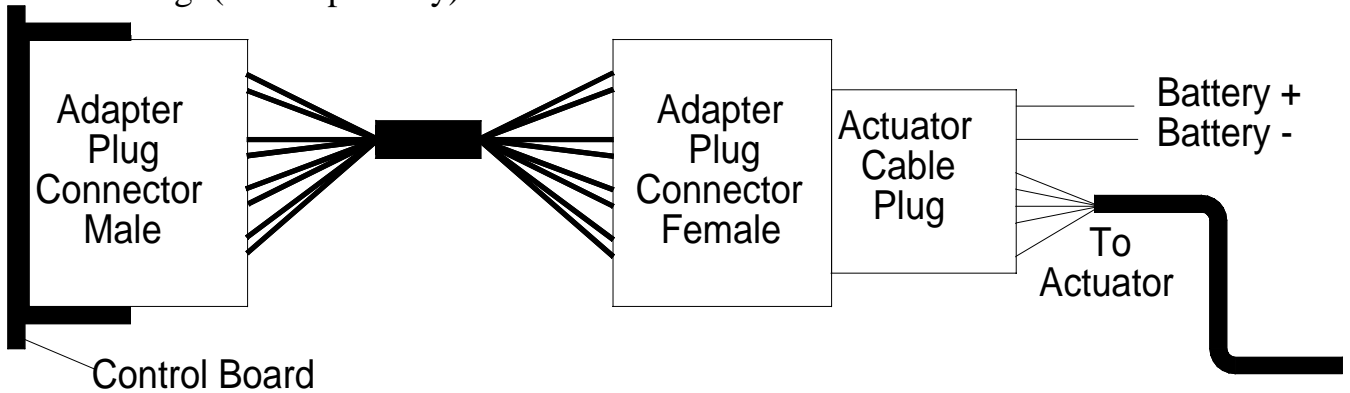

Optional Method

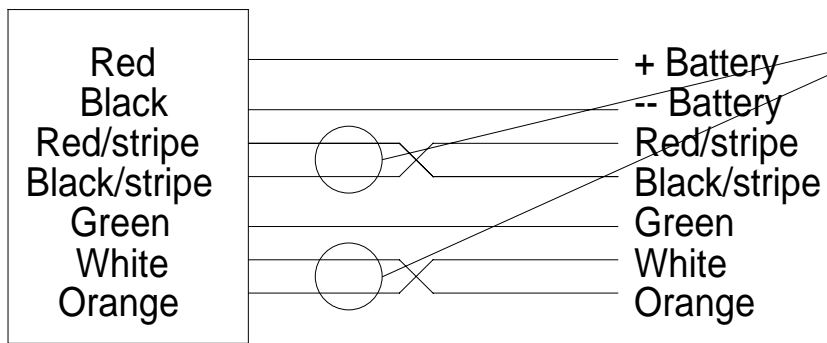

Cut approximately 8" from plug and reconnect with suitable wire nuts or crimp connectors as shown.

Emergency Manual Release

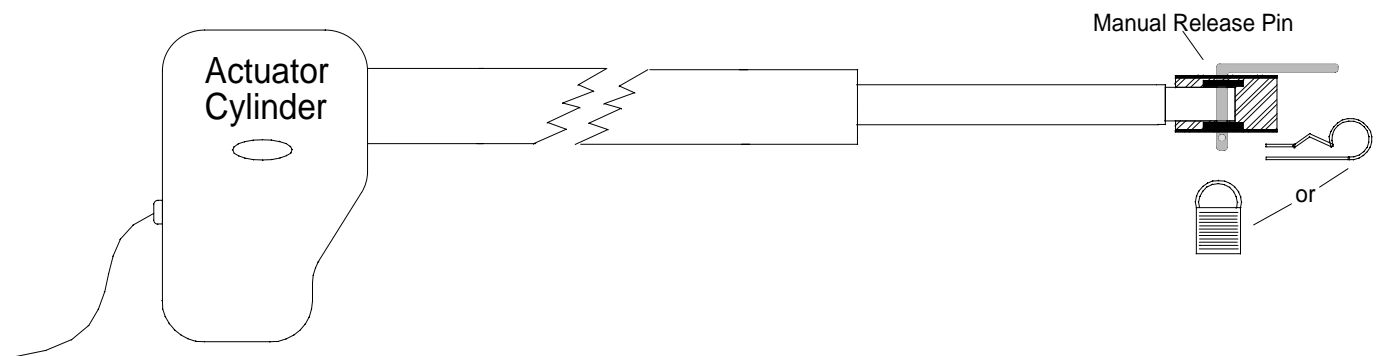

Remove the manual release pin at the gate bracket and open the gate by hand. Secure the gate before attempting to pass through.

SAFETY SECTION

USAutomatic gate operators are manufactured to meet or exceed all UL325 Vehicular Class I and Class II swing gate standards.

UL325 identifies four different classes of gate operators these classes are listed below:

Class I: Residential vehicular gate operator- A vehicular gate operator (or system) intended for use in a home of one to four single family dwellings or a garage or parking area associated therewith.

Class II: Commercial/General access vehicular gate operator- A vehicular gate operator (or system) intended for use in a commercial location or building such as multi-family housing unit (five or more single family units), hotel garages, retail store, or other buildings servicing the general public.

Class III: Industrial/Limited access vehicular gate operator- A vehicular gate operator (or system) intended for use in an industrial location or building such as a factory or loading dock area or other locations not intended to serve the general public.

Class IV: Restricted Access vehicular gate operator- A vehicular gate operator (or system) intended for use in a guarded industrial location or building such as an airport security area or other restricted access locations not servicing the general public, in which unauthorized access is prevented via supervision by security personnel.

Star I and Star II gate operators are intended to be installed as Class I or Class II vehicular gate operators, and the maximum load of each gate leaf should not exceed 300 pounds with a length not to exceed twelve feet.

SECONDARY ENTRAPMENT DEVICES

USAutomatic has designed all control boards with secondary entrapment device inputs and Secondary safety devices must be installed with all installations. USAutomatic recommends the use of the following devices and has provided herein instructions for the connection of such devices.

NOTE: *USAutomatic recommends that these devices be CONNECTED after proper gate installation and operation has been verified. Then connect one device and verify proper operation before installing the next device.*

SAFETY SECTION

Recommended Secondary Entrapment Devices

Contact Safety Devices:

Manufacturer - Miller Edge

<u>Model</u>	<u>Description</u>
MGR20	3 sided protection fitted for 2” round frame
MGS20	3 sided protection fitted for 2” square frame
ME120	1-sided protection attaches to flat surface
MG020	1-sided protection attaches to flat surface
ME123	1-sided protection attaches to flat surface
ME110	
ME111	

Non-Contact Safety Device:

Manufacturer – EMX Industries INC.

<u>Model</u>	<u>Description</u>
IRB-325	+12vdc Photo Eye

Siren (Entrapment Alarm) Devices:

Manufacturer – Signaling Systems

<u>Model</u>	<u>Description</u>
PZ	Piezoelectric siren, 128db +12vdc

NOTE: *For information about installation or applications, consult factory.*

SERVICE

All gate operators require periodic checking and adjustments by a qualified technician of the control mechanism for force (load), speed and sensitivity. All external accessories and secondary safety devices must be checked. Secondary safety devices need to be checked at least once a month for proper operation.

SAFETY SECTION

INSTALLATION

Install the gate operator when:

- The operator is appropriate for the construction of the gate and the usage class is correct for the installation.
- All exposed pinch points are eliminated or guarded.
- Only install on vehicle gates, pedestrians must be supplied with a separate access opening.
- The gate is installed in a location where enough space is supplied between adjacent structures and the gate that when opening or closing the chance of entrapment is reduced.
- Swing gates shall not open into public access areas.
- The gate is properly installed and swings freely in both directions. Do not over adjust the sensitivity adjustment to compensate for an improper gate installation.
- Locate all controls at least six feet away from the gate to eliminate the chance of the person operating the gate from coming in contact with the moving gate. Do not install external buttons, which can be used to operate the gate within the reach of children.
- All placards must be installed one on each side of the gate visible in the gate area.
- Contact sensors used for secondary entrapment safety devices and their wiring must be installed in a manner protects them from mechanical damage.
- Non-Contact sensors used for secondary entrapment safety devices must be located so that the signal from the transmitter to the receiver is not interfered with by adjacent structures. All exposed wiring must also be protected from mechanical damage.

SAFETY SECTION

WARNING: TO REDUCE THE RISK OF INJURY OR DEATH

- 1. READ AND FOLLOW ALL INSTRUCTIONS**
- 2. Never let children operate or play with gate controls. Keep remote control away from children.**
- 3. Always keep people and objects away from the gate.**
- 4. NO ONE SHOULD CROSS THE PATH OF A MOVING GATE.**
- 5. Test gate operator monthly. The gate must stop and reverse directions upon contacting a rigid object or when the secondary entrapment device is activated.**
- 6. After all adjustments have been made to the limit switches, sensitivity (current sense) circuit, secondary entrapment devices and all other external devices installed the safety devices must be checked again. Failure to adjust and retest the gate operator can increase the risk of injury or death.**
- 7. Verify that the emergency release (manual release) pin can be easily removed. This should only be checked when power is disconnected from the operator.**
- 8. KEEP GATES PROPERLY MAINTAINED. Read the user manual and have a qualified service technician make repairs to the gate hardware.**
- 9. THE ENTRANCE IS TO BE USED BY VEHICLES ONLY. Pedestrians must use a separate entrance.**
- 10. SAVE THESE INSTRUCTIONS**

SAFETY SECTION

All safety features required by UL 325 are incorporated in the capabilities of all USAutomatic Control boards and should be utilized, including but not limited to, safety edges, photo electric eyes, reverse sensing, and motion sensing.

Cautions - Very Important

- Do not attempt to enter the gate area while the gate is moving. Wait until the gate comes to a complete stop.
- Operate the gate only when it is fully visible, free of persons or obstructions, and properly adjusted.
- Do not allow children to play in the area of the gate. Do not allow anyone to ride on the gate.
- Do not allow children to play with the remote control or any other activation device.
- Do not attempt to "beat the gate" while the gate is opening or closing. This is extremely dangerous.
- Test the current sense feature and all safety devices regularly to insure correct operation.
- Study this entire Safety Section paying particularly close attention to the entrapment zones shown below and be aware of these areas not on during use but also during any adjustments to the unit.

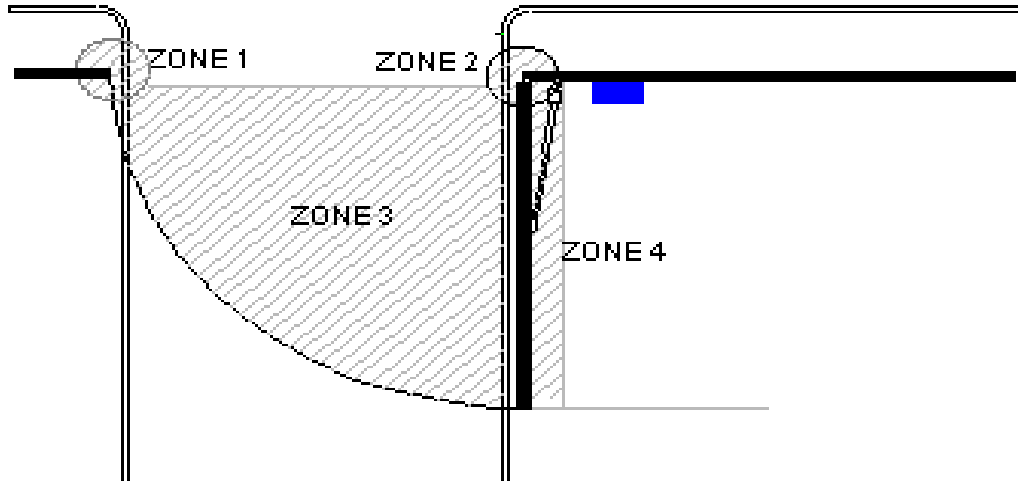

ENTRAPMENT ZONES

- Zone 1 The leading edge of the gate & catch post.
- Zone 2 Between the gate and hinge post.
- Zone 3 The arc of the gate or gate path.
- Zone 4 The space between the gate when open and any obstruction such as fence, wall, landscaping, etc.
- Zone 5 (Not shown) the point where two bi-parting gates come together when closing. This is similar to Zone 1.

SAFETY SECTION

Remedies for Safety Concerns

Zone 1 Safety edge and photo electric eyes are the most common types of protection available.

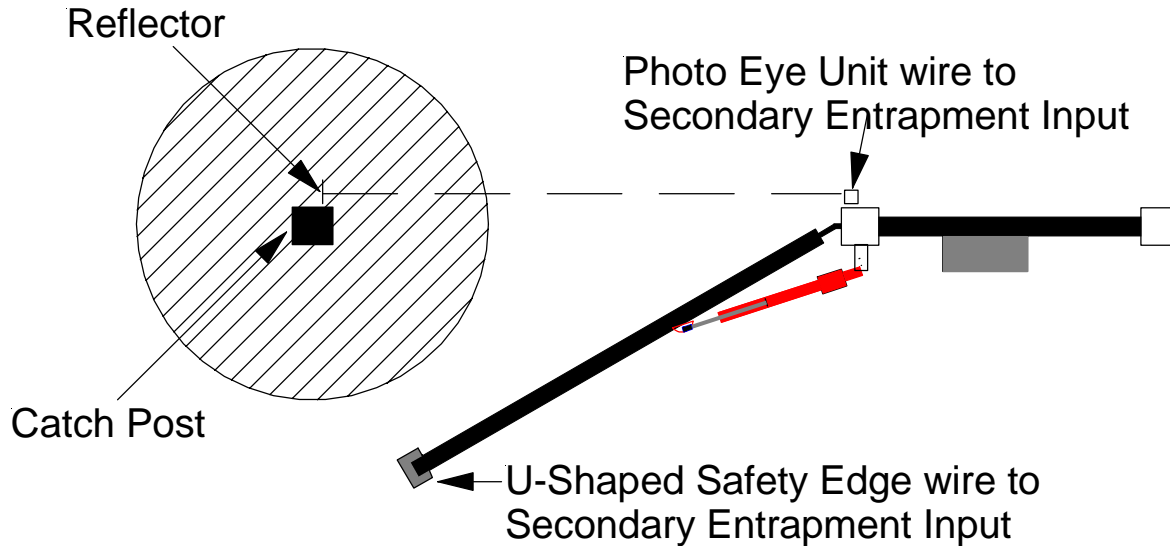

Zone 2 A safety edge may also be utilized here but the best remedy is to eliminate pinch points when designing the hinges. Most injuries at this point result from negligence, such as reaching through the hinge area or the gate to activate a button, keyswitch, etc.

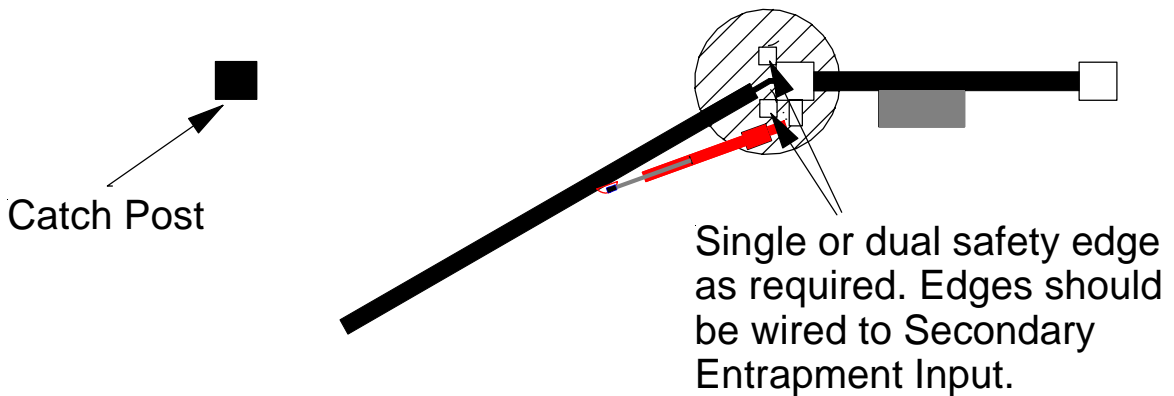

NOTE: *All control stations should be located at least 6 feet from any moving part of the gate or operator.*

Never install any control device where a user will be tempted to reach through the gate or fence to activate a gate.

SAFETY SECTION

Remedies for Safety Concerns

Zone 3 Safety edges are the best protection. A photo eye may also be used. For vehicle traffic, magnetic vehicle detectors and wire sensing loops are preferred.

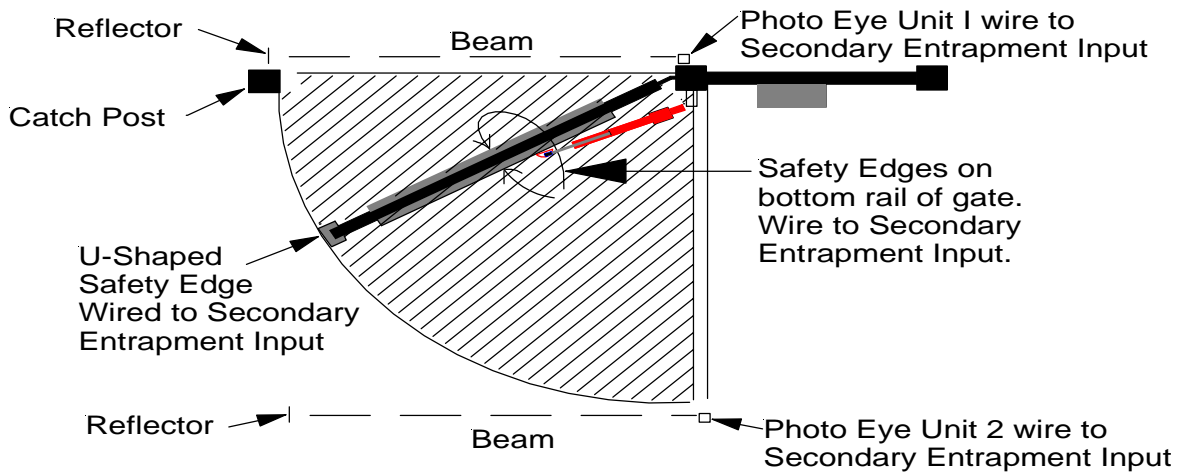

Zone 4 This area is best protected with a photo eye wired to Safety reverse input (Secondary Entrapment). The beam should be installed parallel to the gate in the open position or along the obstructing wall or fence.

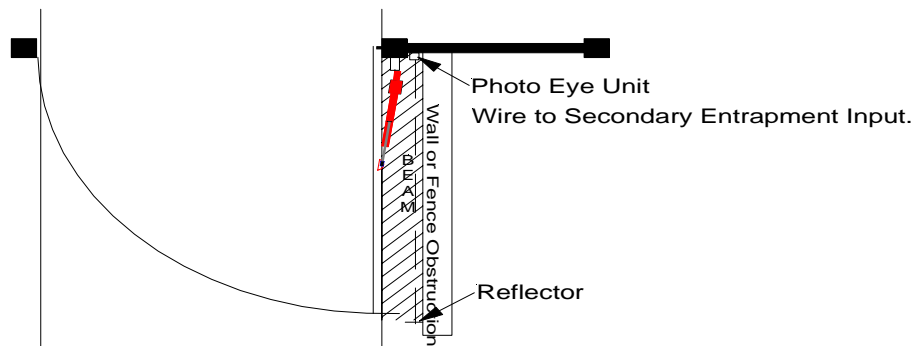

Zone 5 Safety edges and photo eyes are the most common types of protection available.

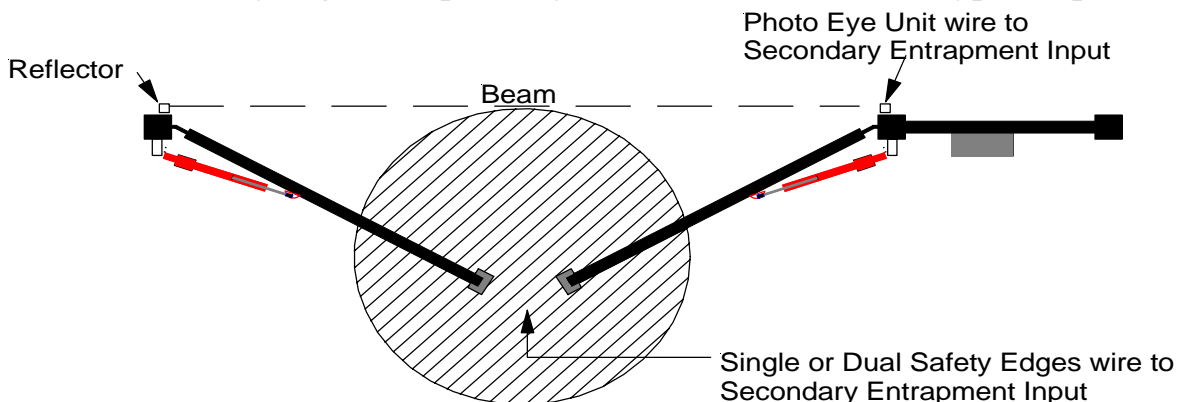

Every installation is unique and it is the installer's responsibility to recognize and remedy all safety concerns. Please consult a qualified dealer or the factory for a complete explanation of the remedies shown above and additional tips pertaining to your installation.

Troubleshooting Guide

Introduction

The USAutomatic control board is equipped with two unique features to assist in troubleshooting a gate system.

1. The first and most helpful is the series of LED indicating lights. These lights will help to identify problems with the actuator limit switches and the receiver input. To use the indicators, press and hold the Push Button Led button on the control board. (The lights are not active at all times to save battery life). Any circuits or limit switches that are activated will be obvious by the illumination of the adjacent LED indicating light.
2. The second feature to assist in troubleshooting is the on board Open/Close Pushbutton. This button makes it possible to operate the gate with the twelve terminal wiring plug removed without having to short across terminal pins.

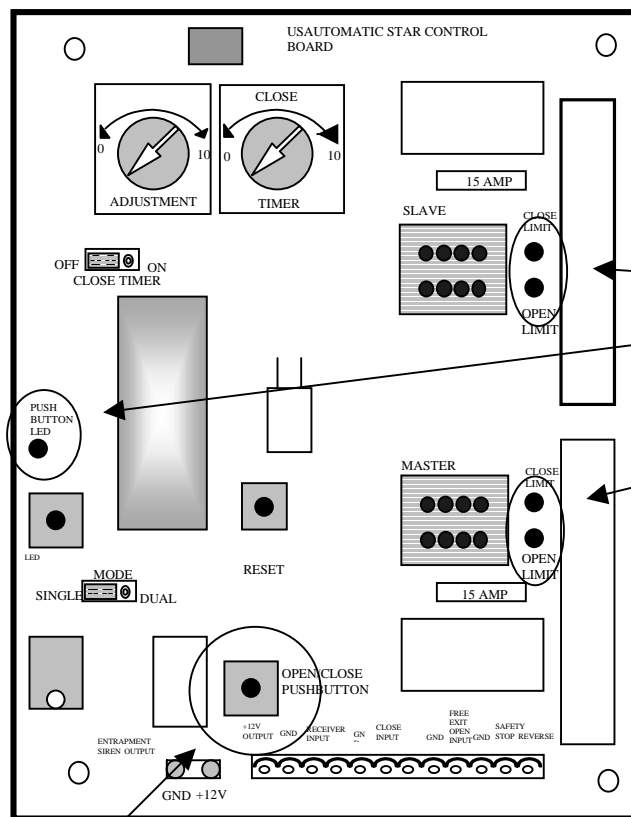

LED INDICATING LIGHTS

Open/Close Pushbutton

TROUBLESHOOTING GUIDE

<i>SYMPTOM</i>	<i>POSSIBLE CAUSE</i>	<i>REMEDY</i>
1. Gate stops and reverses direction in mid-travel.	<ul style="list-style-type: none"> a. Current sense feature may be set too sensitive. b. Gate operator is not plumb & level. c. Gate or hinges are binding or are not plumb and level. d. Low battery voltage. e. Control board is defective. f. Shaft seal on actuator is binding due to dryness. This usually occurs in colder weather or first cycle in the morning. 	<p>Readjust- see page 15. CAUTION: Sensitivity should be sensitive enough to avoid injury.</p> <p>Remount hinge mount tube or gate bracket.</p> <p>Repair gate and readjust all actuator and board settings.</p> <p>Check battery/at least 12.5 volts DC.</p> <p>Replace control board.</p> <p>Spray stainless actuator shaft with silicone spray lube or spread a very light film of all-purpose grease on shaft.</p>
2. Gate travels OK but after closing, opens back up.	<ul style="list-style-type: none"> a. Too much travel distance on closing cycle. b. Actuator cable damaged or loose connections. c. Control board is defective. 	<p>Readjust closing limit switch See page 16.</p> <p>Check actuator plug at control board and cable for nicks or tears.</p> <p>Replace control board.</p>
3. Gate doesn't move at all.	<ul style="list-style-type: none"> a. Blown fuse b. Loose or incorrect battery connections or voltage. c. Actuator cable damaged or loose connection. d. Actuator limit switch assembly defective. e. Control board is defective. f. A control device such as a push-button, remote control, keyswitch, etc. is shorted, which will lock up the circuit board. 	<p>Replace if blown with 15-amp max.</p> <p>Check battery connections, polarity and voltage/at least 12.5 volts DC.</p> <p>Check actuator plug at control board and cable for nicks or tears.</p> <p>Replace or repair actuator.</p> <p>Replace control board.</p> <p>Remove signal wires from these devices one at a time until board will activate.</p>

TROUBLESHOOTING GUIDE

<i>SYMPTOM</i>	<i>POSSIBLE CAUSE</i>	<i>REMEDY</i>
4. Gate will not open with remote control transmitter.	<p>a. Improper code settings or wiring.</p> <p>b. Weak transmitter battery.</p> <p>c. Poor antenna connection.</p>	<p>Check the code switches in the transmitter & receiver. Verify that they are identical. Check wiring of receiver.</p> <p>Replace battery. LED light should illuminate on remote.</p> <p>Check all connections and/or raise the antenna to avoid metal objects.</p>
5. Gate activates open or close for no reason.	<p>a. A shorted signal is coming into the control board from an external control device such as a remote transmitter, pushbutton, key pad, etc.</p>	<p>Check all transmitters and pushbuttons for a stuck button. Remove signal wires from control board one at a time until unit returns to normal. Replace defective device or wires.</p>
6. Automatic close timer will not close the gate.	<p>a. An opening device such as a button, keypad, phone unit, or exit loop detector is shorted.</p> <p>b. A safety device such as a safety loop detector or safety edge is shorted.</p> <p>c. A wire from one of these devices is shorted.</p> <p>d. Close timer jumper not properly installed or missing.</p> <p>e. Defective control board.</p>	<p>Remove each device from the system one at a time until gate times out to close.</p> <p>Remove each device from the system one at a time until gate times out to close. Use on board indicating lights to assist in locating the shorted circuit.</p> <p>Test cables by removing one at a time until timer times out and gate closes. Use on board indicating lights to assist in locating the shorted circuit.</p> <p>Install jumper (see page 18)</p> <p>Replace control board.</p>
7. Gate jerks excessively when activated and bounces during cycle.	<p>a. Hinge mount tube dimensions are not correct.</p> <p>b. Hinge post is weak.</p> <p>c. Gate design is weak.</p> <p>d. Gate bracket is not mounted secure enough.</p>	<p>Remount hinge mount tube per instructions.</p> <p>Replace or reinforce post.</p> <p>Replace or reinforce gate.</p> <p>Remount bracket and reinforce surrounding area.</p>

TROUBLESHOOTING GUIDE

<p>8. Gate began to operate increasingly slower and does not operate at all now.</p>	<p>a. Battery has one or more dead cells.</p> <p>b. If AC charged, circuit breaker has tripped or power to charger is interrupted.</p> <p>c. Battery charging system (AC charger or solar panel) is not functioning.</p>	<p>Replace battery.</p> <p>Check circuit breaker. Check for power at charger receptacle.</p> <p>Consult factory for testing instructions. (Test meter required).</p>
<p>9. On a dual gate, only one unit will open and close.</p>	<p>a. Blown fuse</p> <p>b. Defective actuator.</p> <p>c. Defective cable.</p> <p>d. Defective control board.</p> <p>e. Master/Slave jumper not properly installed or is missing.</p> <p>Note: <i>Reverse actuator plugs on board and actuator locations to determine exact cause of problem.</i></p>	<p>Replace with 15-amp max.</p> <p>Repair or replace actuator.</p> <p>Repair or replace cable.</p> <p>Repair or replace control board.</p> <p>Install jumper (see page 18)</p>

Accessory Wiring Diagrams

Single Button Station to Open/Close

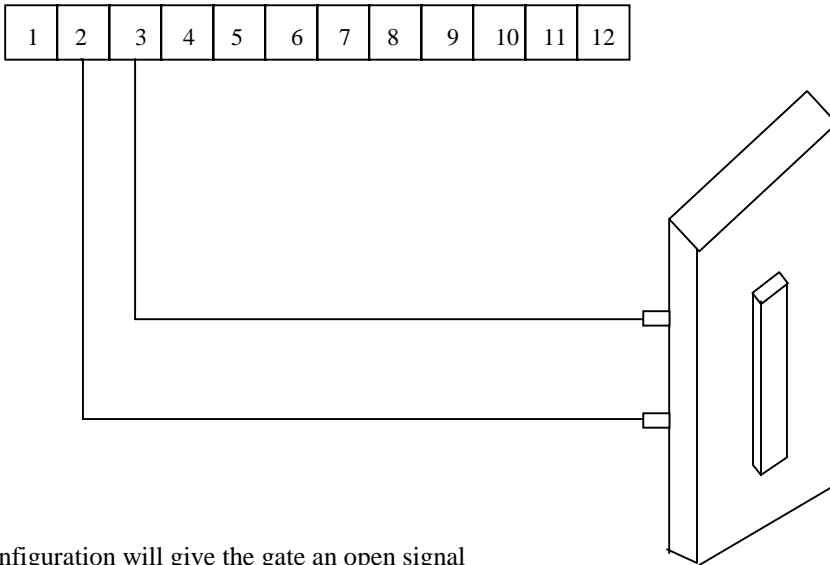

This configuration will give the gate an open signal if the gate is closed and a close signal if the gate is open.

Radio Receiver Multi-Code 1099-40/Linear DRG-LV

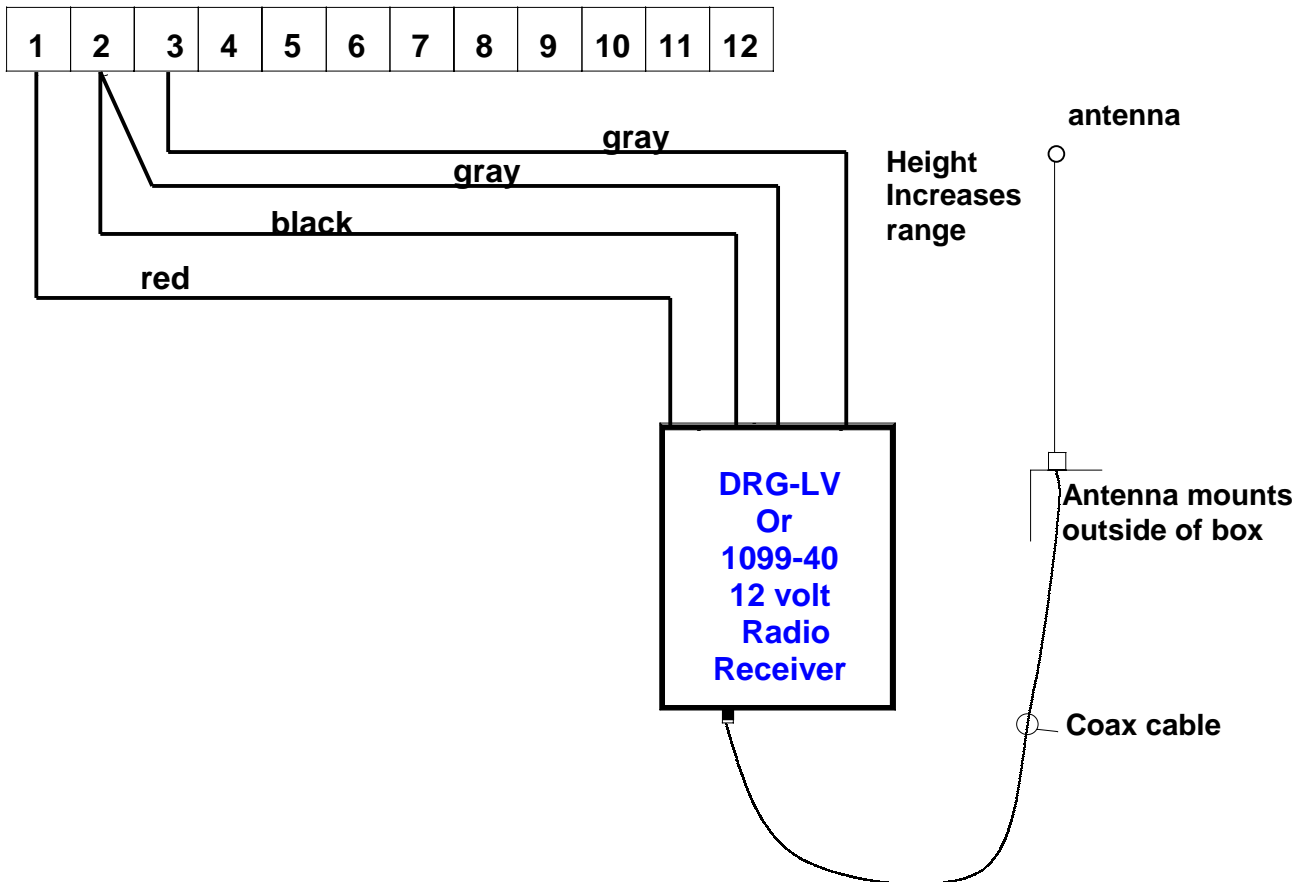

Radio Receiver Allister 9931-LV 3 wire with F Connector

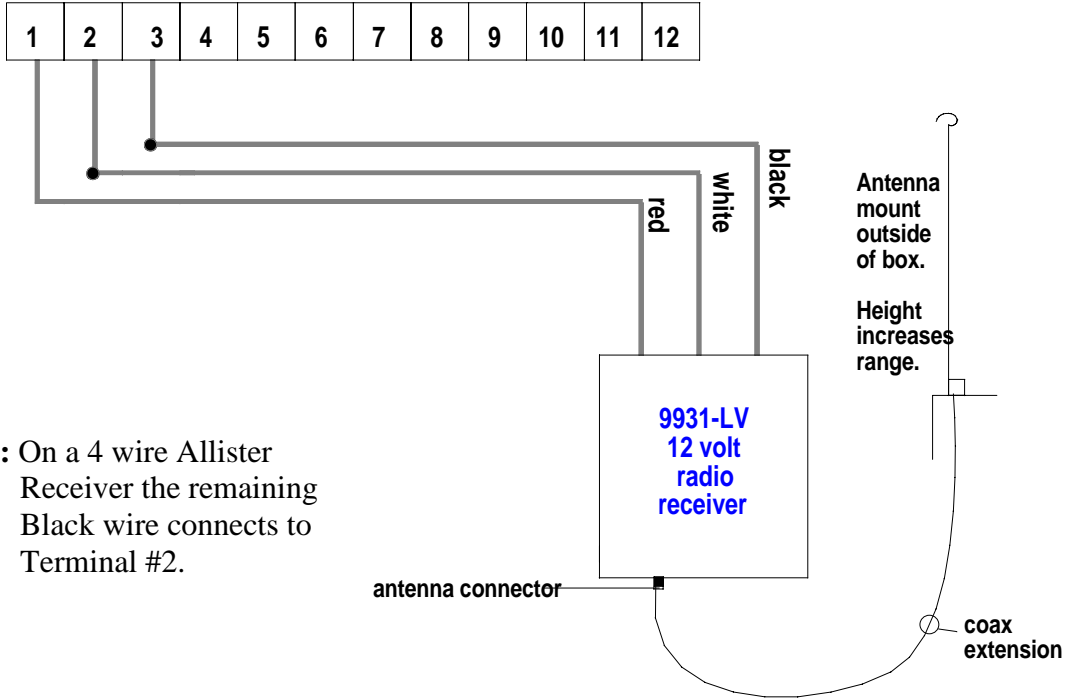

Note: On a 4 wire Allister Receiver the remaining Black wire connects to Terminal #2.

Radio Receiver Liftmaster 412 HM

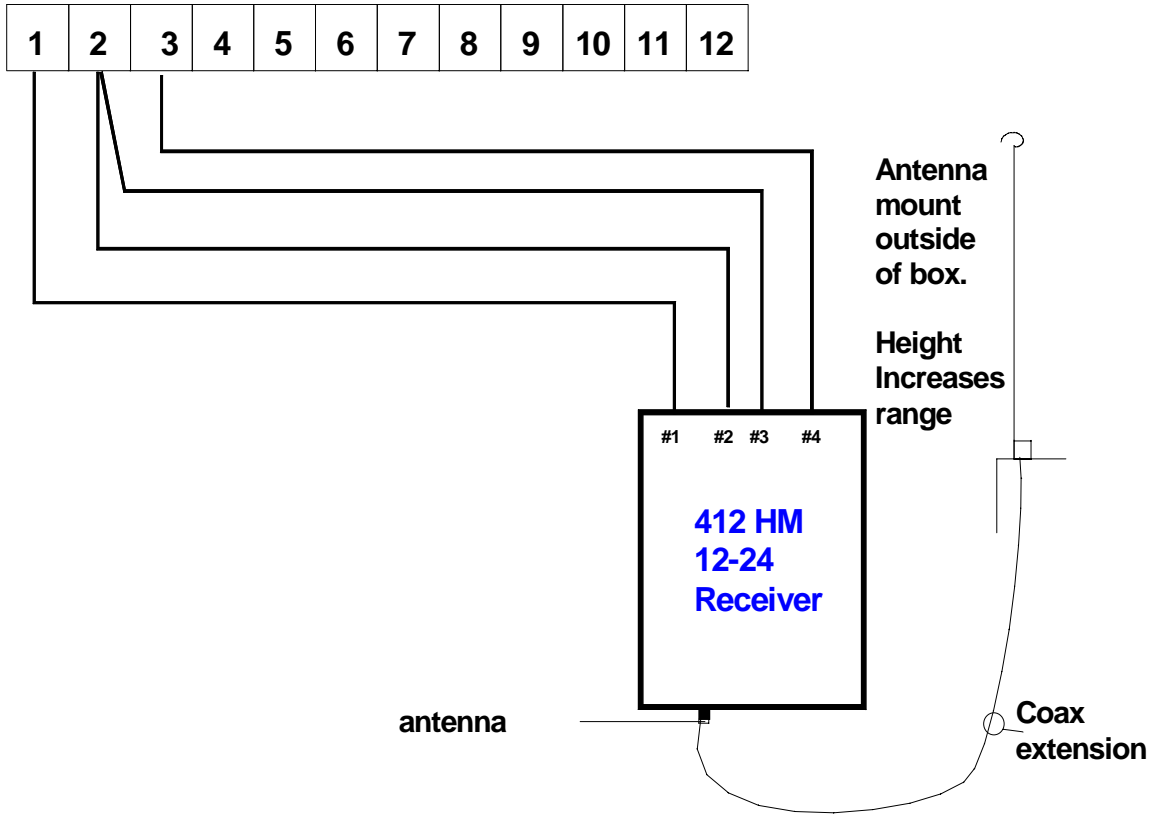

Radio Receiver Linear DRA-F 12 Volt

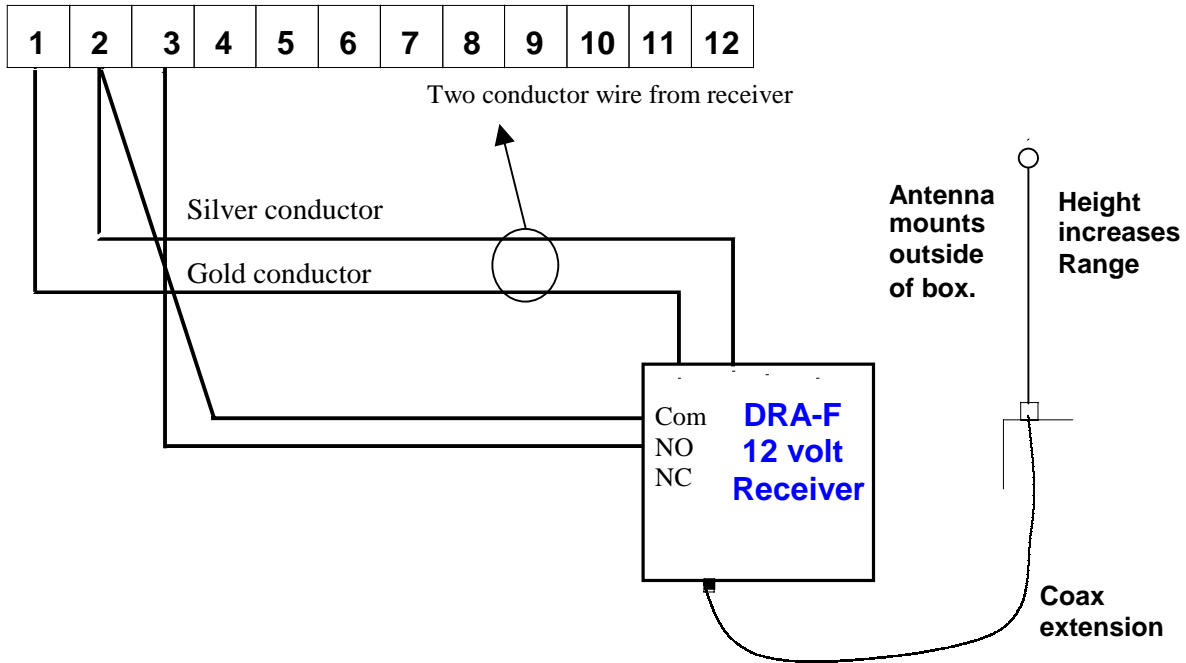

Keypad (12 Volt D.C.)

Momentary Contact Signal

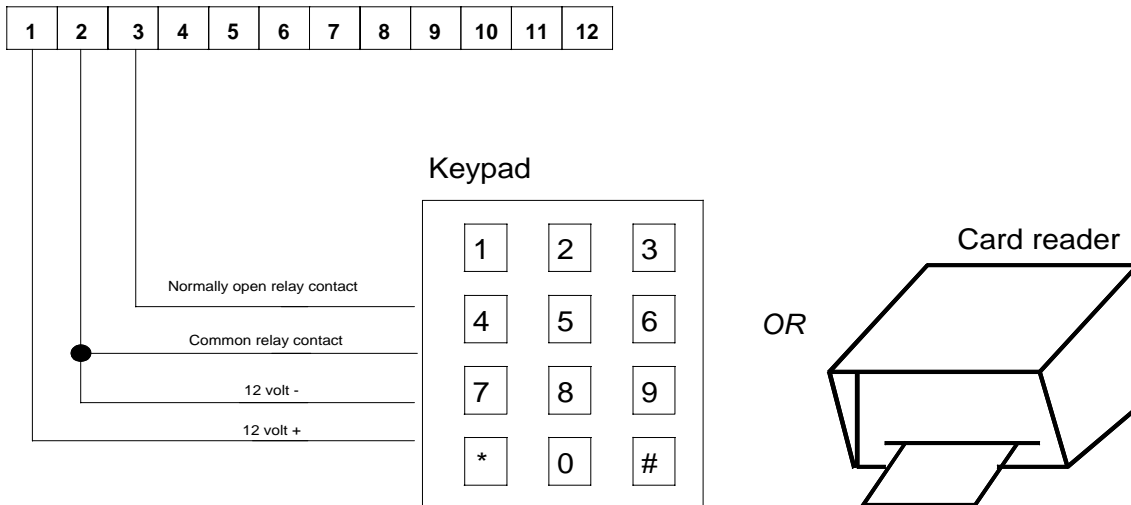

Note: If your keypad is equipped with a maintain contact code and you are using the code to override the auto close timer circuit, move the #3 wire to #9.

Telephone Access Unit Wiring Signal or Hold Open Signal

(Hold open circuit with timer to close override)

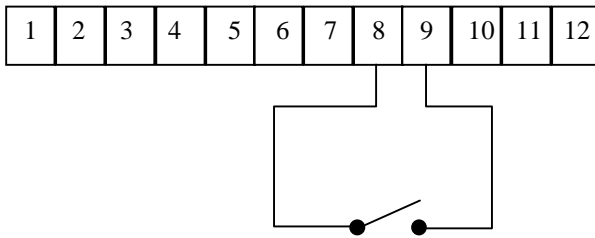

Normally open contacts from any device such as a Free Exit Loop Detector, maintain contact keyswitch, toggle switch, 7 day timer, telephone access unit, etc. When the switch contacts close, the gate will open and remain open until the contacts are released. The close timer or any close signal can now activate the gate.

Photo Eye Wiring for Secondary Entrapment Device

+12 volt Photo Eye

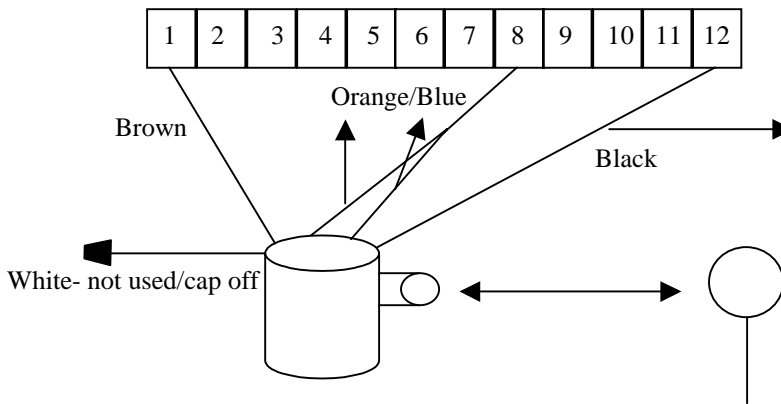

Shown for Secondary Entrapment device
For safety stop, move black wire to pin 11.
For free exit move black wire to pin 9.

*Stop circuit wiring also available, consult factory

Safety Edge Wiring (Wired Type) Secondary Entrapment Device

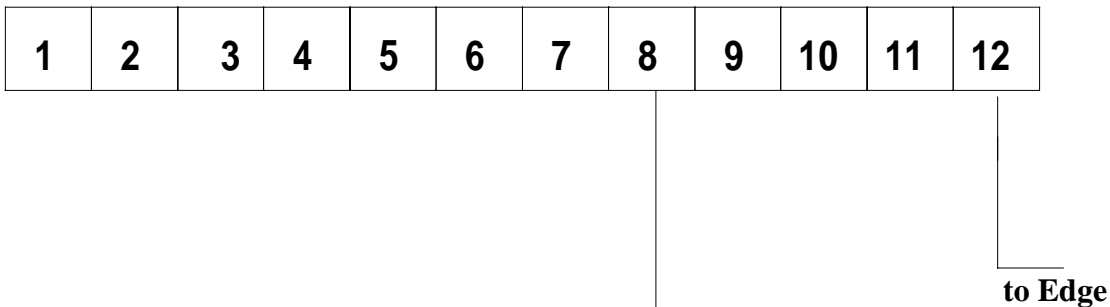

*Stop circuit wiring also available, consult factory

Safety Edge Wiring (Wireless Type) Secondary Entrapment Device

Safety Edge Transmitter & Radio Receiver

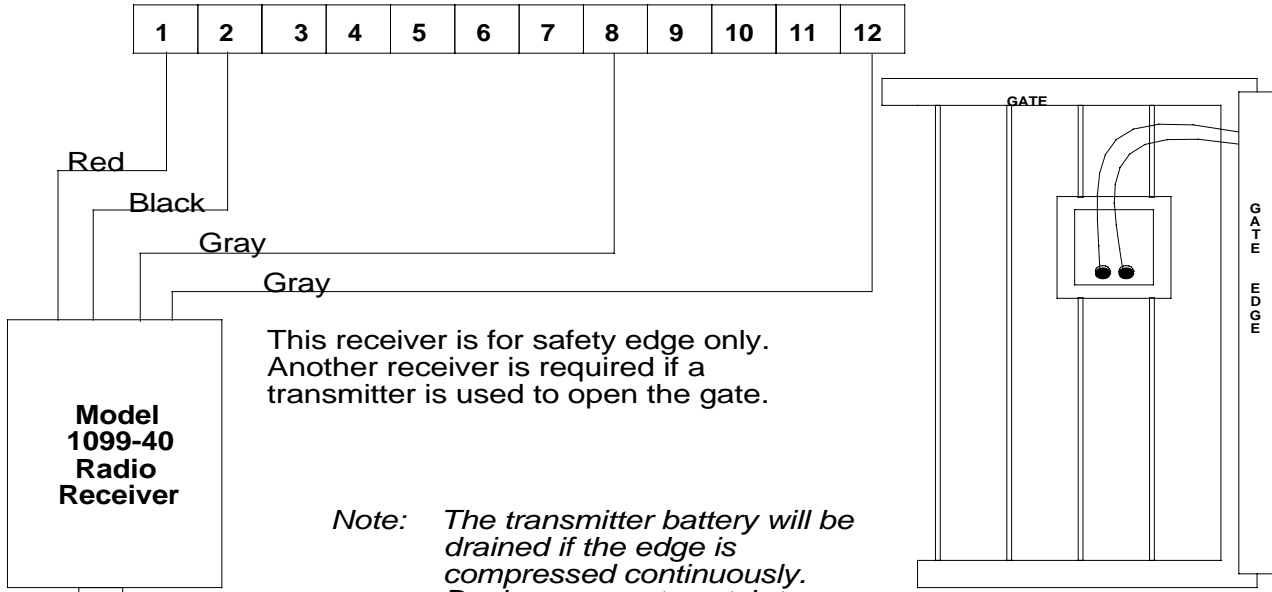

Use coax antenna to locate antenna outside of control box.

*Stop circuit wiring also available, consult factory

Siren Secondary Entrapment

Output designed for +12vdc
Sirens less than 1 amp.

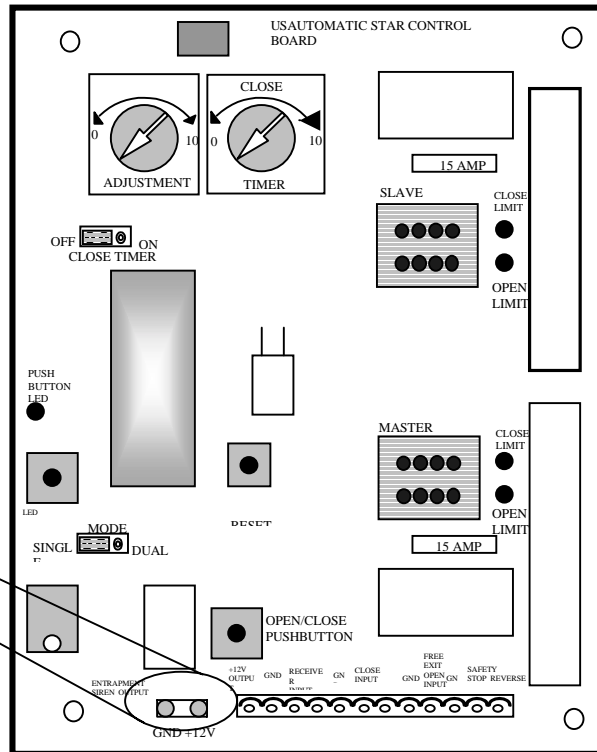
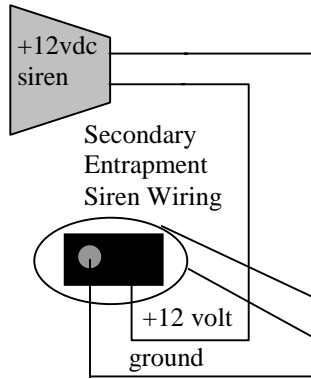

Safety Magnetic Vehicle Detector 12 Volt DC

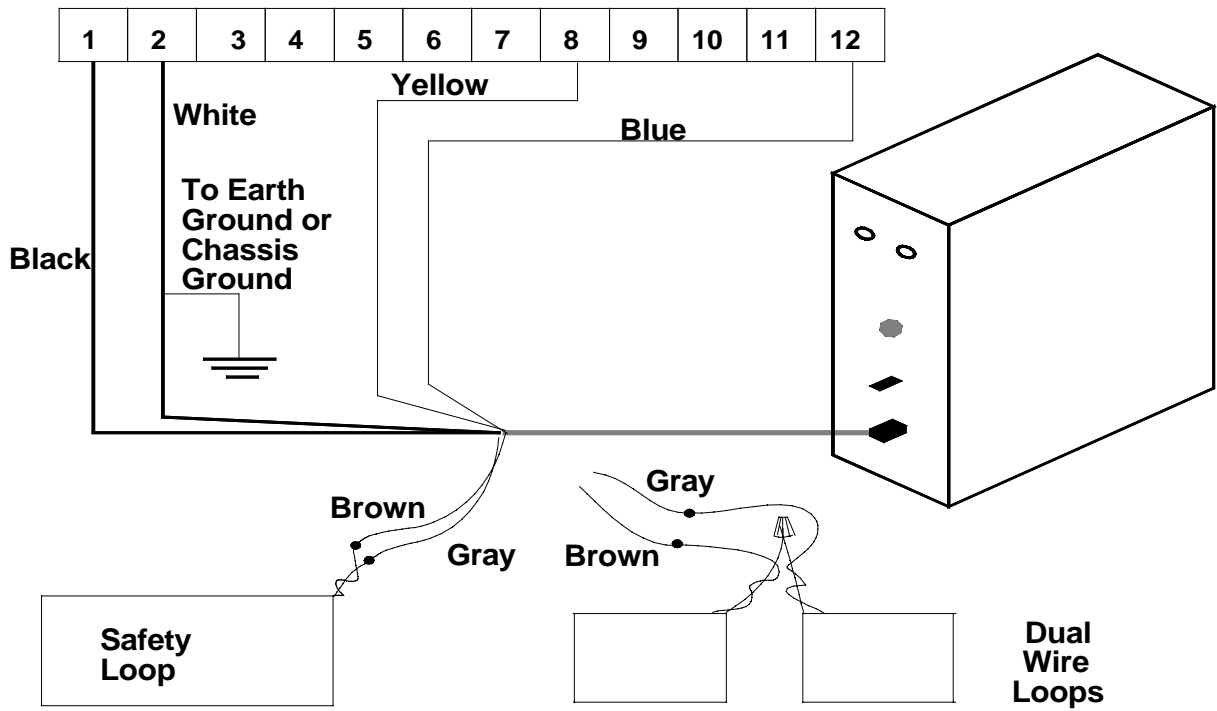

Free Exit Magnetic Vehicle Detector 12 Volt DC

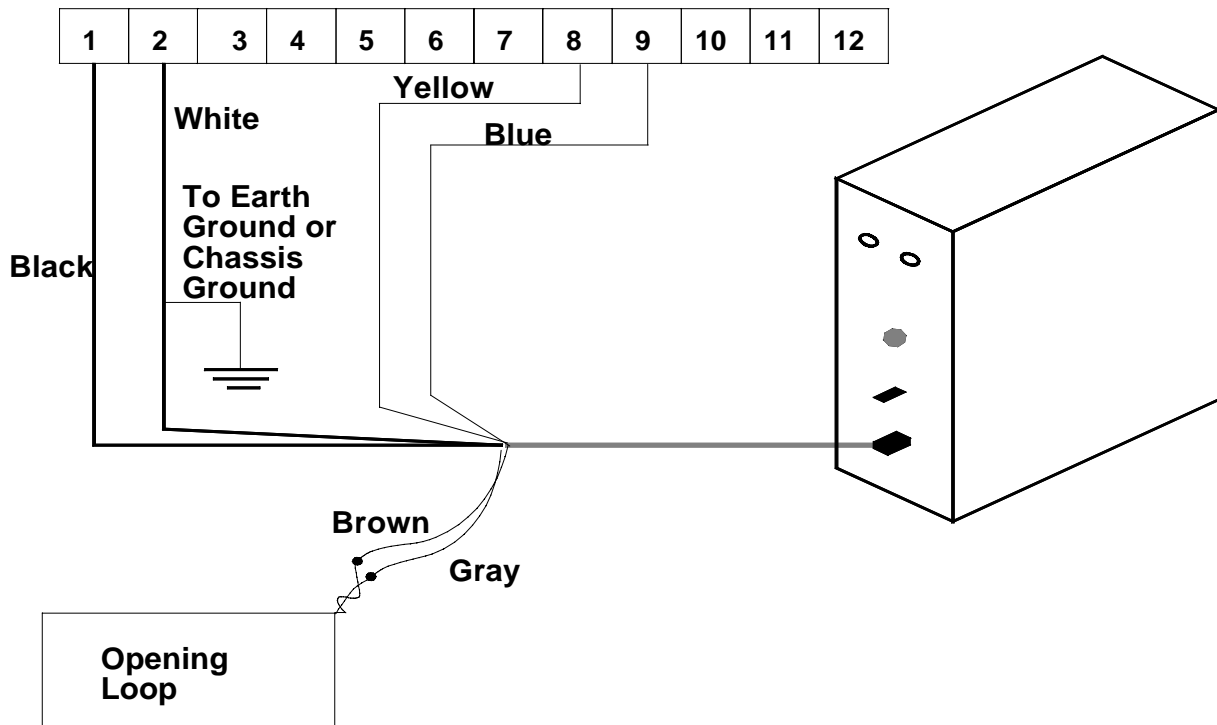

Probe Type Free Exit Magnetic Detector - MFM-376 LC Kit

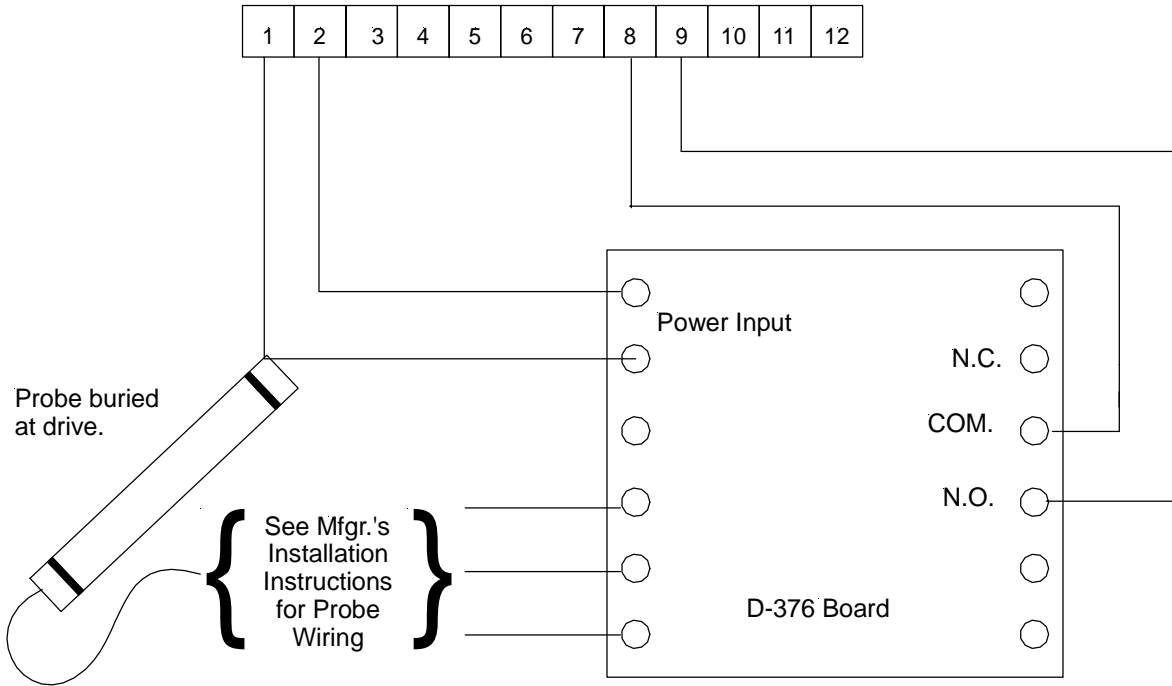

NOTE: This type of detector senses moving vehicles only. It should be utilized as an opening device only. If used as a safety device, the gate will close if the vehicle stops and possible damage will result.

Seven-Day Timer to Hold Gate Open - TH800-12

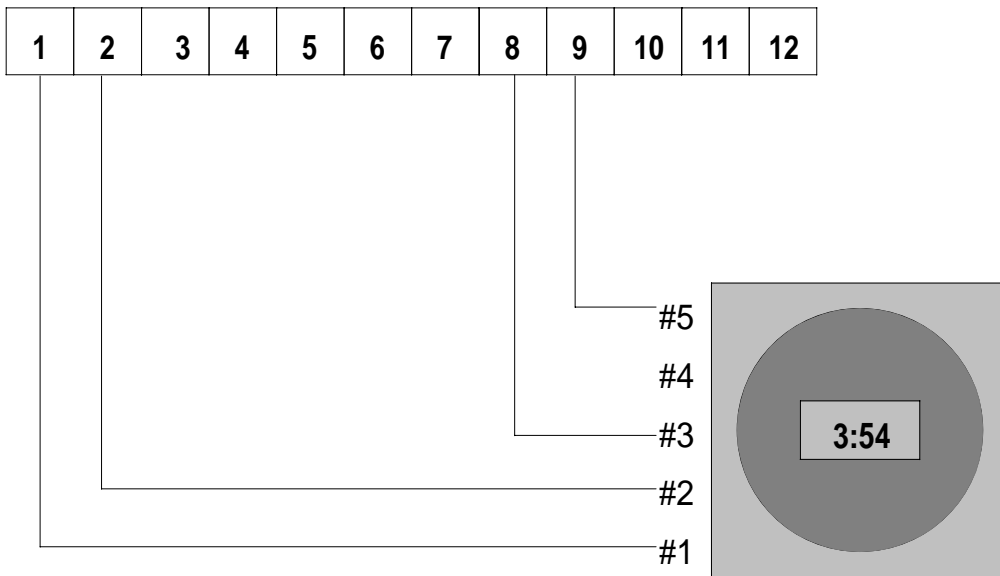

Loops

Loop Position Diagram

Single Swing Gate with 2 Loops

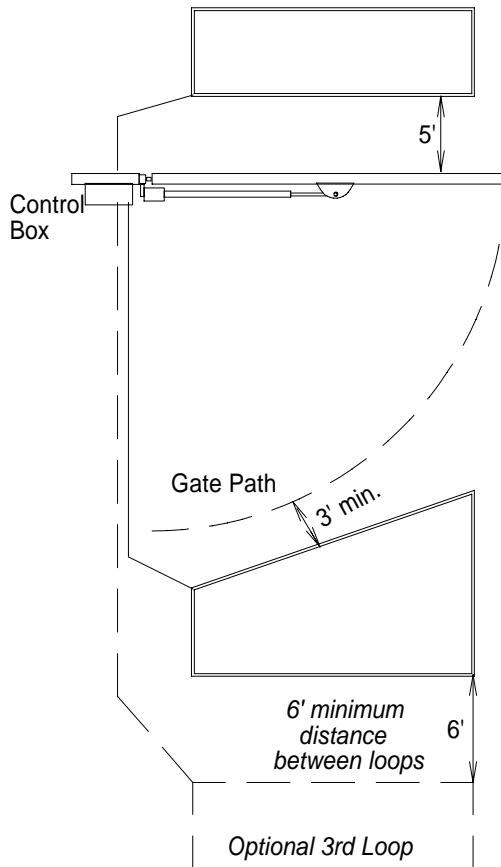

Dual Swing Gate with 2 Loops

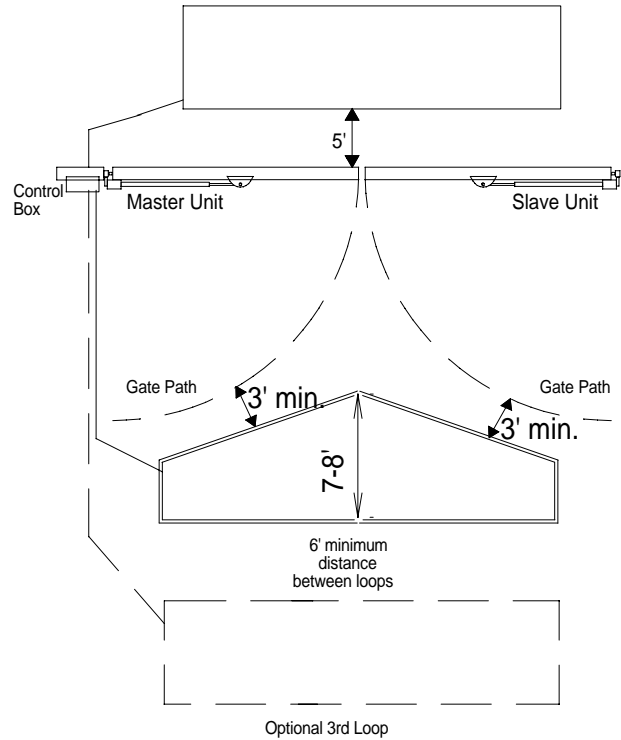

Proper wiring of two loops performing the same function.

Example: Inside and Outside Safety Loops

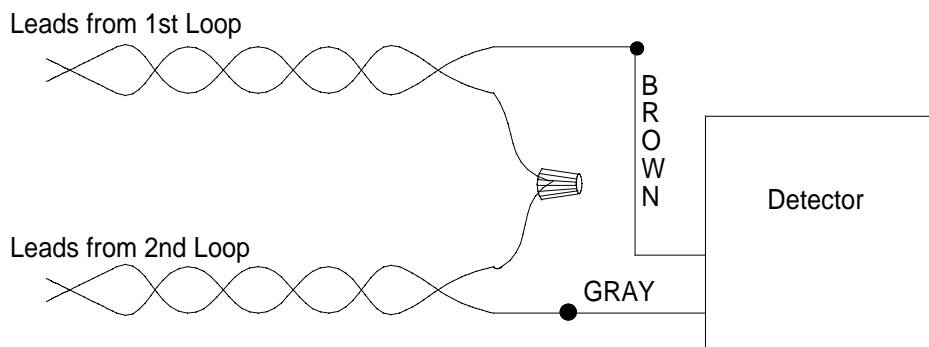

Loops

Typical Loop Saw cut

TOP VIEW



Corners should be cross-cut as shown for stress relief. 45 degrees is maximum turn angle allowed. Sawcut width must be at least 1/8" for recommended wire. Lead in slot must be at least 1/4" for twisted leads.

SIDE VIEW

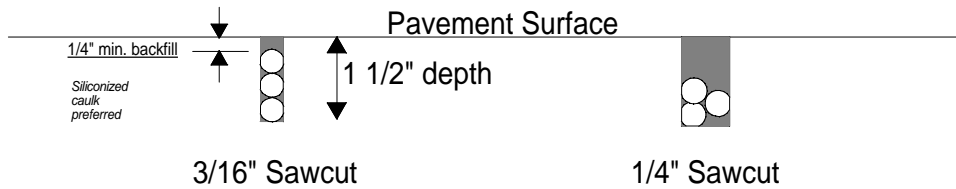

Center Loop

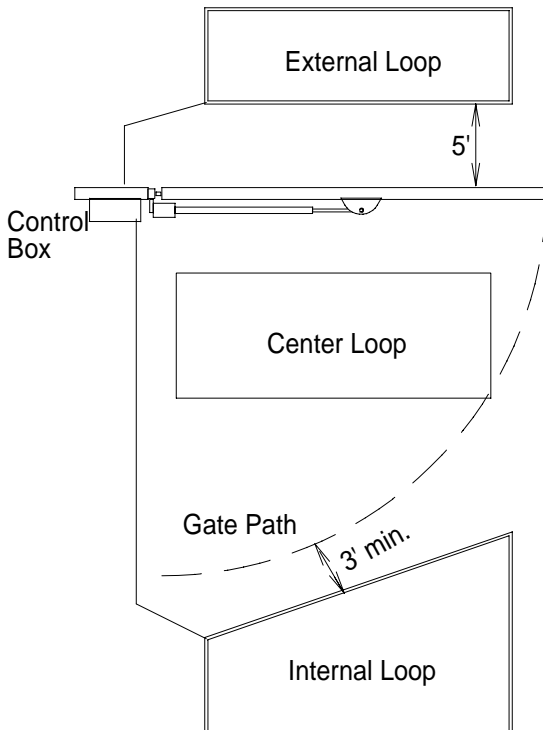

For larger gates, a loop can be placed directly under the gate. A separate detector is required. The loop will only be active when the gate is fully open and will ignore the signal at all other points. Consult a dealer or the factory for a complete explanation.

Loops

Loop Size Chart

The loop size is based on the width of the driveway. If the driveway is 14' wide, the loop would be a 6'x6', the minimum. This is determined by subtracting 4' off of each side of the drive, which would leave you 6'.

See chart below for number of turns per loop size, plus lead in.

The loop itself should contain between 90 & 125 feet of wire in the loop, plus lead in.

<u>Drive Width</u>	<u>Loop Size</u>	<u>Number of Turns</u>		
		<u>2</u>	<u>3</u>	<u>4</u>
14' & Under	6' x 6'			96'
16'	6' x 8'			112'
18'	6' x 10'		96'	
20'	6' x 12'		108'	
22'	6' x 14'		120'	
24'	6' x 16'		132'	
26'	6' x 18'	96'		

The location of the loop is also important. If a loop is located too close to the gate, it will detect the gate itself, giving false operation. If the loop is too far away from the gate a small vehicle might not be detected. Loops should be approximately 5' from the center line of a gate when closed. See Loop Position on previous 2 pages.

Loops

Other Loop Detector Facts

1. Always clean saw cuts thoroughly with water, air or brush to remove all debris prior to installing wire.
2. Recommended loop wire is TFFN #16 gauge stranded wire. It is available at electric supply distributors.
3. No splices are permitted in the loop or loop leads. One continuous wire should be used.
4. Lead wires should be twisted a minimum of 4 twists per foot to eliminate false sensing. Twists should begin at the edge of the loop and continue to detector.
5. Do not use metal or sharp objects to push the loop wire into the saw cut. The slightest nick or cut in the insulation will cause the loop to ground out and malfunction. To test for shorts, use a megohmmeter or "Megger" between either loop lead and earth ground with both leads disconnected from the detector. The resistance should be greater than 50 megohms.
6. Use siliconized caulk for backfill. Gray for concrete, black for asphalt. 25-Year life rating is preferred.
7. Never set adjacent loops on the same frequency. False activation will occur.
8. Almost all brands of detectors have an external or internal sensitivity adjustment. Usually the factory setting is sufficient if internal adjust type. Be very careful and use extreme caution when decreasing sensitivity.
9. Most false activations are caused by an improperly installed loop or a shorted loop. The loop should be tested and validity determined before adjusting sensitivity. See # 5 above.
10. Most detectors used in the gate business are fail-safe. This means that if the loop fails, the gate will be given a continuous signal. When power is disconnected from a detector, the signal output is also given.
11. ASB, or automatic sensitivity boost is now available on most detectors. This feature should be activated if large truck or trailer traffic is likely.

To: USAutomatic
419 Southfork
Suite D
Lewisville, TX 75057

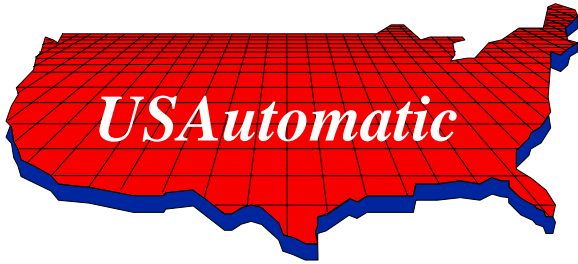

**Star I
Star II**
Limited 5 Year Warranty

The Star Gate Operator is warranted to be free of defects in materials or workmanship for a period of 5 years from date of purchase on the electronic control board and 12 months on all other components. Any part, parts, or complete unit found to be defective within this period will, at the manufacturer's option be repaired or replaced at no charge if returned freight prepaid. New or factory rebuilt replacement parts are warranted for the remaining portion of the original warranty period. The manufacturer will pay for standard ground freight on the return of the repaired or replaced items under this warranty. The manufacturer will not be responsible for field service or labor charges incurred in the removal or replacement of defective parts. Furthermore, the manufacturer will not be responsible for incidental or consequential damages. This warranty is in lieu of all other warranties expressed or implied and shall be considered void if damage was due to improper use or installation, connection to an improper power source, or if caused by fire, flood, lightning and other acts of nature, or by vehicles or vandalism. This warranty gives you specific legal rights, and you may have other rights, which vary from state to state. Some states do not allow limitations or exclusions of implied warranties so these may not apply to you.

Keep this portion for your records

Model: _____ **Serial Number*:** _____

Date of Purchase: _____ **Purchased from:** _____

CUT HERE

RETURN THIS PORTION TO:
USA Automatic
419 Southfork, Suite D
Lewisville, Texas 75057
Toll Free 1-888-204-0174

Model: _____ Date of Purchase: _____
Serial #: _____ Purchased from: _____
Name: _____
Address: _____
City: _____ State: _____ Zip: _____

**Serial number can be found by removing cover and looking on control board.*